

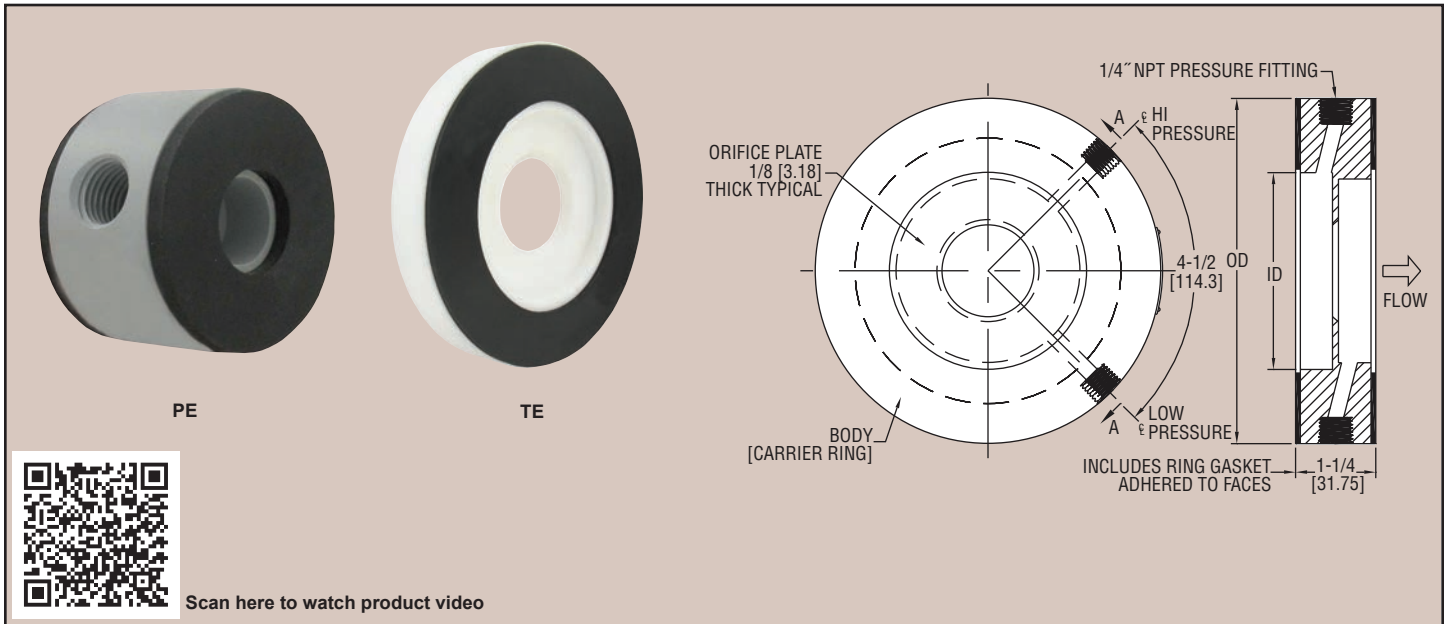

Series  
PE & TE

# Orifice Plate Flowmeters

PVC or PTFE Orifice Plates



Scan here to watch product video

The **Series PE Orifice Plate Flow Meter** offers one-piece PVC construction incorporating a unique holder or carrier ring containing metering taps and integral gaskets. Unlike a standard orifice plate, the Series PE is a true primary element including the various components for differential pressure measurement. It was designed for use wherever there is an application for a conventional flow orifice plate. It can also be used in place of other primary differential producers for efficiency and cost effectiveness. The Series PE is available in line sizes from 1/2" to 24" and used for air and most gases. It meets or exceeds ASME, AGA & ISO standards.

#### SERIES PE FEATURES

- Mounted with standard flanges
- Standard "corner tap" configuration
- Corrosion free material
- Simplified installation
- Built in metering taps (1/4" female NPT STD)
- Proven through a wide range of applications for accuracy and energy efficiency
- Assures long term reliability and accuracy

The **Series TE Orifice Plate Flowmeter** offers one-piece PTFE construction similar to the OP and PE Series orifice plates, which incorporate a unique holder or carrier ring containing metering taps and integral gaskets. Available for line sizes from 1/2" to 24", the Series TE orifice plate can be used with gases, liquids, corrosive, and high temperature fluids. The Series TE can be easily installed by slipping the unit between standard flanges (orifice flanges are not required). The Series TE was designed for use anywhere there is an application for a conventional flow orifice plate. It can also be used in place of other primary differential producers for efficiency and cost effectiveness.

#### SERIES TE FEATURES

- Excellent chemical resistance
- Weather resistant
- Flame retardant (without factory gaskets)
- Low friction (minimum wear)
- Orifice plate thickness 1/4" offering greater stability

#### SPECIFICATIONS

- Service:** PE: Clean air and compatible gases; TE: Compatible gases and liquids.
- Wetted Material:** Monolithic (single piece) constructed entirely of gray PVC for PE or white PTPE for TE, Buna-N gaskets.
- Accuracy:** ±0.6% full scale flow. (Beta = .2-.6) ±0.7% for Beta greater than .6.
- Temperature Limits:** PE: 140°F max (60°C max); TE: -40 to 200°F (-40 to 93.3°C).
- Pressure Limits:** 150 psi (10 bar) max.
- Head Loss:** 1-Beta ratio<sup>2</sup> eg: 1 - 0.7<sup>2</sup> = 1 - 0.49 = 51% of the d.p.
- Line Sizes:** 1/2" to 24".
- Process Connections:** 1/4" female NPT.
- Installation:** Standard flange 125#/150# rating.
- Pipe Requirements:** General requirements 10 diameter upstream and 5 diameter downstream.
- Weight:** Varies with line size. See chart.

**Series PE Orifice Plate Flowmeter – Air Capacity Structure**

- Material PVC- Gaskets Buna-N
- Based on 70°F, 14.7 psia (Base Conditions)
- Beta Value Based on Std Sch pipe I.D.
- 1.25" overall thickness
- Orifice plate thickness is 0.125"

**Series TE Orifice Plate Flowmeter – Capacity Structure**

- Material PTFE - Gaskets Buna-N
- Based on 70°F, 14.7 psia (base conditions)
- Beta value based on Std Sch pipe I.D.
- 1.25" overall thickness
- Orifice plate thickness is 0.250"

PE Model	PE Weight (lb)	TE Model	TE Weight (lb)	Line Size	Bore	Beta	Water Capacity (TE)		Air Capacity - Flow in SCFM			
							in d.p. w.c.	Flow in GPM	in d/p w.c.	at 14.7 psia (0 psig)	at 20 psig	at 100 psig
PE-A-1	1.00	TE-A-1	1.00	1/2"	0.200"	0.3	20	0.62	20	2.35	3.63	6.61
PE-A-2	1.00	TE-A-2	1.00	1/2"	0.310"	0.5	100	3.44	100	12.21	19.58	36.37
PE-A-3	1.00	TE-A-3	1.00	1/2"	0.430"	0.69	320	13.00	200	32.77	56.15	107.47
PE-B-1	1.00	TE-B-1	1.00	3/4"	0.250"	0.3	20	0.97	20	3.65	5.66	10.3
PE-B-2	1.00	TE-B-2	1.00	3/4"	0.400"	0.49	100	5.69	100	20.21	32.44	60.26
PE-B-3	1.00	TE-B-3	1.00	3/4"	0.580"	0.7	320	23.82	200	59.92	102.91	197.2
PE-C-1	1.00	TE-C-1	1.00	1"	0.300"	0.29	20	1.38	20	5.24	8.11	14.8
PE-C-2	1.00	TE-C-2	1.00	1"	0.520"	0.49	100	9.63	100	34.2	54.92	102.09
PE-C-3	1.00	TE-C-3	1.00	1"	0.720"	0.69	320	36.15	200	91.28	156.51	300
PE-D-1	1.00	TE-D-1	1.00	1.25"	0.400"	0.29	20	2.46	20	9.31	14.41	26.3
PE-D-2	1.00	TE-D-2	1.00	1.25"	0.700"	0.51	100	17.48	100	62.09	99.75	185.5
PE-D-3	1.00	TE-D-3	1.00	1.25"	1.00"	0.72	320	71.77	200	180	309.97	595.2
PE-E-1	2.00	TE-E-1	2.00	1.5"	0.500"	0.31	20	3.85	20	14.57	22.55	41.16
PE-E-2	2.00	TE-E-2	2.00	1.5"	0.800"	0.5	100	22.73	100	80.82	129.68	241.5
PE-E-3	2.00	TE-E-3	2.00	1.5"	1.100"	0.68	320	83.95	200	212.18	363.93	697.39
PE-F-1	2.00	TE-F-1	2.00	2"	0.600"	0.29	20	5.52	20	20.92	32.38	59.13
PE-F-2	2.00	TE-F-2	2.00	2"	1.000"	0.48	100	35.34	100	125.74	202.03	375.8
PE-F-3	2.00	TE-F-3	2.00	2"	1.450"	0.7	320	147.74	200	372.09	639.87	1227.63
PE-G-1	2.00	TE-G-1	2.00	2.5"	0.750"	0.3	20	8.63	20	32.71	50.64	92.48
PE-G-2	2.00	TE-G-2	2.00	2.5"	1.250"	0.5	100	55.54	100	197.54	317.58	590.91
PE-G-3	2.00	TE-G-3	2.00	2.5"	1.750"	0.7	320	216.30	200	543.99	936.56	1798.86
PE-H-1	2.00	TE-H-1	2.00	3"	0.920"	0.3	20	12.97	20	49.17	78.13	139.06
PE-H-2	2.00	TE-H-2	2.00	3"	1.500"	0.49	100	79.94	100	282.9	454.77	846.21
PE-H-3	2.00	TE-H-3	2.00	3"	2.150"	0.7	320	324.16	200	816.7	1404.95	2696.28
PE-J-1	3.00	TE-J-1	3.00	4"	1.200"	0.3	20	22.03	20	83.58	129.44	236.48
PE-J-2	3.00	TE-J-2	3.00	4"	2.000"	0.5	100	141.51	100	503.76	810.06	1507.64
PE-J-3	3.00	TE-J-3	3.00	4"	2.800"	0.7	320	547.11	200	1380.03	2373.02	4553.68
PE-K-1	3.00	TE-K-1	4.00	5"	1.500"	0.3	20	34.39	20	130.48	202.11	369.29
PE-K-2	3.00	TE-K-2	4.00	5"	2.500"	0.5	100	220.80	100	786.23	1264.42	2353.51
PE-K-3	3.00	TE-K-3	4.00	5"	3.500"	0.69	320	853.09	200	2152.83	3701.57	7103.22
PE-L-1	4.00	TE-L-1	4.00	6"	1.800"	0.3	20	49.46	20	187.86	291	531.75
PE-L-2	4.00	TE-L-2	4.00	6"	3.000"	0.49	100	317.74	100	1331.63	1820.05	3387.93
PE-L-3	4.00	TE-L-3	4.00	6"	4.200"	0.69	320	1226.98	200	3097.20	5325.20	10219.28
PE-M-1	5.00	TE-M-1	6.00	8"	2.400"	0.3	20	87.95	20	333.87	517.25	945.28
PE-M-2	5.00	TE-M-2	6.00	8"	4.000"	0.5	100	565.77	100	2014.95	3241.45	6034.85
PE-M-3	5.00	TE-M-3	6.00	8"	5.600"	0.7	320	2195.86	200	5532.00	9525.43	18290.00
PE-N-1	6.00	TE-N-1	8.00	10"	3.000"	0.3	20	137.35	20	521.58	808	1476.77
PE-N-2	6.00	TE-N-2	8.00	10"	5.000"	0.5	100	883.04	100	3145.50	5060.38	9421.74
PE-N-3	6.00	TE-N-3	8.00	10"	7.000"	0.7	320	3421.26	200	8626.42	14846.80	28506.17
PE-O-1	7.00	TE-O-1	10.00	12"	3.600"	0.3	20	197.73	20	750.9	1163.44	2126.47
PE-O-2	7.00	TE-O-2	10.00	12"	6.000"	0.5	100	1271.62	100	4530	7288.16	13570.33
PE-O-3	7.00	TE-O-3	10.00	12"	8.400"	0.7	320	4930.86	200	12430.00	21397.00	41089.02
PE-P-1	9.00	TE-P-1	15.00	14"	4.000"	0.3	20	244.14	20	927.14	1436.59	2625.81
PE-P-2	9.00	TE-P-2	15.00	14"	6.600"	0.5	100	1537.49	100	5477.67	8812.87	16409.42
PE-P-3	9.00	TE-P-3	15.00	14"	9.300"	0.7	320	6052.57	200	15251.50	28262.66	50437.78
PE-Q-1	10.00	TE-Q-1	18.00	16"	4.500"	0.3	20	308.76	20	1172.63	1817.05	3321.32
PE-Q-2	10.00	TE-Q-2	18.00	16"	7.600"	0.5	100	2038.95	100	7264.58	11688.26	21764.08
PE-Q-3	10.00	TE-Q-3	18.00	16"	10.700"	0.7	320	8007.74	200	20179.85	34749.32	66737.64

Note: Differential pressure values should be less than 50% of the inlet absolute pressure.