

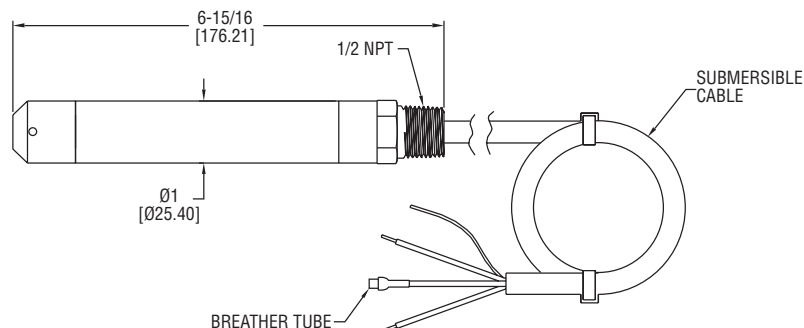

Series SBLTX Submersible Level Transducer

Specifications - Installation and Operating Instructions



The **SBLTX Submersible Level Transducer** is manufactured for years of trouble free service. The transducer consists of a piezoresistive sensing element, encased in a 316 SS housing. Bullet nose design protects diaphragm from damage. Comes equipped with a 270-pound tensile strength, shielded, vented cable. Ventilation tube in the cable automatically compensates for changes in atmospheric pressure above the tank.

Intrinsic Safety Approval Classification

The SBLTX is UL listed for use in Hazardous (Classified) Locations. The protection method is by Intrinsic Safety, "ia". It was investigated by UL under UL Standard 913 Sixth Edition and CSA Standard No. 157-92.

For use in Hazardous (Classified) Locations:

Class I Div. 1 Groups A,B,C,D

Class II Div. 1 Groups E,F,G

Class III Div. 1

Temperature Code: T4 @ 80°C ambient

Install in accordance with control drawing 01-700797-00.

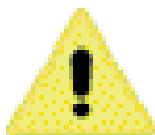

WARNING: To prevent ignition of flammable or combustible atmospheres, disconnect power before servicing.
Use with approved safety barriers using entity evaluation.

Entity Parameters

V _{max}	I _{max}	C _i	L _i	P _i
28VDC	93mA	0.051_F	240_H	0.651W

SPECIFICATIONS

Service: Compatible liquids.

Wetted Materials: 316 SS, 316L SS, epoxy adhesive; Cable: Polyether polyurethane or ETFE; Bullet Nose: PVC.

Accuracy: ±0.25% of full scale.

Temperature Limit: 0 to 176°F (-18 to 80°C).

Compensated Temperature Range: 0 to 176°F (-18 to 80°C).

Thermal Effect: Less than ±0.02% full scale/ °F.

Pressure Limit: 2X full scale.

Power Requirement: 10 to 28 VDC.

Output Signal: 4 to 20 mA DC, 2-wire.

Response Time: 50 ms.

Max. Loop Resistance: 900 ohms.

Electrical Connections: Wire pigtail.

Mounting Orientation: Suspended in tank below level being measured.

Weight: 2.2 lb (1.0 kg).

Agency Approvals: CE, cULus Intrinsically Safe to UL Standard 913. (See Intrinsic Safety Approval Classification.)

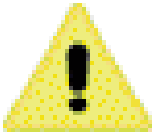

CAUTION: Do not exceed specified supply voltage ratings. Permanent damage not covered by warranty will result. This device is not designed for 120 or 240 volt AC operation. Use only on 10 to 28 VDC.

MAINTENANCE

After final installation of the pressure transducer and its companion receiver, no routine maintenance is required. A periodic check of system calibration is suggested. The Series SBLTX transducer are not field repairable and should be returned if repair is needed (field repair should not be attempted and may void warranty). Be sure to include a brief description of the problem plus any relevant application notes. Contact customer service to receive a return goods authorization number before shipping.

INSTALLATION

1. Location: Select a location where the temperature of the transducer will be between 0 and 176°F (-18 to 80°C). Distance from the receiver is limited only by total loop resistance.

2. Position: The transducer is not position sensitive. However all standard models are originally calibrated with the unit in a position with the pressure connection downward. Although they can be used at other angles, for best accuracy it is recommended that units be installed in the position calibrated at the factory.

3. Mounting: The transducer can be mounted via several methods. It can be suspended from the electrical cable, it can be placed resting on the bottom of the tank in either horizontal or vertical orientation, or it can be attached to a pipe or hang wire by the 1/2" NPT male connection on the top of the housing.

4. Electrical Connections

Wire Length - The maximum length of wire connecting the transducer and receiver is a function of wire size and receiver resistance. Wiring should not contribute more than 10% of the receiver resistance to total loop resistance. For extremely long runs (over 1000 feet), choose receivers with higher resistance to minimize the size and cost of connecting leads. Where wiring length is under 100 feet, wire as small as 22 AWG can be used.

5. Wiring

An external power supply delivering 10-28 VDC with minimum current capability of 40 mA DC (per transducer) is required to power the control loop. See Fig. A for connection of the power supply, transducer and receiver. The range of appropriate receiver load resistance (RL) for the DC power supply receiver voltage available is expressed by the formula:

$$RL \text{ Max} = \frac{V_{ps} - 10V}{20 \text{ mA DC}}$$

Shielded cable is recommended for control loop wiring.

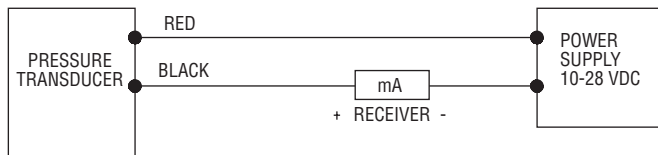

Fig. A

Black wire is negative (-) and red wire is positive (+).

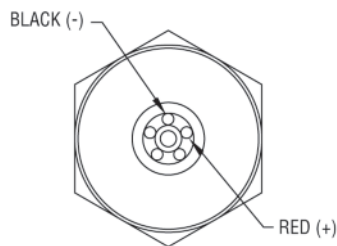

Fig. B

NOTES:

1. MAX SAFE AREA VOLTAGE NOT TO EXCEED 250 VAC.
2. NO REVISIONS WITHOUT PRIOR UNDERWRITERS LABORATORY APPROVAL.
3. (ENTITY CONCEPT DEFINITIONS)

IMPORTANT! NO REVISIONS WITHOUT PRIOR UNDERWRITERS LABORATORIES APPROVAL CAN BE IMPLEMENTED

THE ENTITY CONCEPT ALLOWS INTERCONNECTION OF INTRINSICALLY SAFE APPARATUS TO ASSOCIATED APPARATUS NOT SPECIFICALLY EXAMINED IN SUCH COMBINATION. THE CRITERIA FOR INTERCONNECTION IS THAT THE VOLTAGE AND CURRENT WHICH INTRINSICALLY SAFE APPARATUS CAN RECEIVE AND REMAIN INTRINSICALLY SAFE, CONSIDERING FAULTS, MUST BE EQUAL TO OR GREATER THAN THE VOLTAGE (V_{oc}) AND CURRENT (I_{sc}) LEVELS WHICH CAN BE DELIVERED BY THE ASSOCIATED APPARATUS. CONSIDERING FAULTS AND APPLICABLE FACTORS. IN ADDITION, THE MAXIMUM UNPROTECTED CAPACITANCE AND INDUCTANCE (C_i & L_i) OF THE INTRINSICALLY SAFE APPARATUS, INCLUDING INTERCONNECTING WIRING, MUST BE EQUAL TO OR LESS THAN THE CAPACITANCE AND INDUCTANCE WHICH CAN BE SAFELY CONNECTED TO ASSOCIATED APPARATUS.

4. INSTALLATION MUST BE IN ACCORDANCE WITH THE NATIONAL ELECTRICAL CODE (NFPA 70, ARTICLE 504) AND ANSI/ISA-RP12.6.

HAZARDOUS (CLASSIFIED) LOCATION
 INTRINSICALLY SAFE
 FOR CLASS I DIV.1 GROUPS A,B,C,D
 CLASS II DIV. 1 GROUP E,F,G
 CLASS III DIV. 1
 T4 TEMPERATURE CODE BASED ON 80°C AMBIENT

NONHAZARDOUS LOCATION

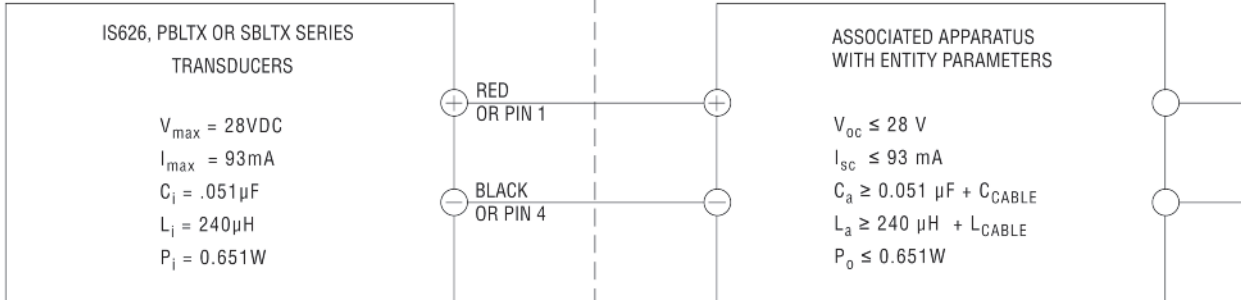

CATALOG NUMBERS:
 IS626-aa-bb-cc-dd-ee-ffff
 PBLTX-aaa-bbb-cccc
 SBLTX-aa-bb-cccc

WHERE:
 a,b,c,d,e & f = ANY LETTER OR NUMBER

Ⓢ = CRITICAL DIMENSION
 STANDARD TOLERANCES UNLESS NOTED:
 ALL DECIMAL DIMENSIONS ± .005
 ALL ANGLES ± 1°

SCALE 1:1

			DATE 7-14-06	NAME BULLETIN ARTWORK INTRINSIC SAFETY CONTROL DRAWING FOR IS626, PBLTX & SBLTX SERIES	MATERIAL
			DWN BY DGH		FINISH
2			CHKD CAT		DWYER INSTRUMENTS, INC. MICHIGAN CITY, INDIANA 46360 U.S.A.
1	ADDED LABELS TO PLUS & MINUS TERMINALS. ADDED P_i & $P_o = 0.651W$ TO BOXES. ECR #21141.	BRENT 1-22-07	APPD SE	ACAD2002	
NO.	CHANGES	BY/DATE			FR. NO. 01-700797-00
NOTICE: This drawing and the principles and elements of design embodied therein are the exclusive property of DWYER INSTRUMENTS, INC. and are not to be communicated, disclosed, reproduced or used except as previously authorized in writing by such corporation and must not be submitted to outside parties for examination without the written consent of said corporation.					3

MERCOID DIVISION
DWYER INSTRUMENTS, INC.
P.O. BOX 258 • MICHIGAN CITY, IN 46360 U.S.A.

Phone: 219/879-8000
Fax: 219/872-9057

www.dwyer-inst.com
e-mail: info@dwyermail.com