

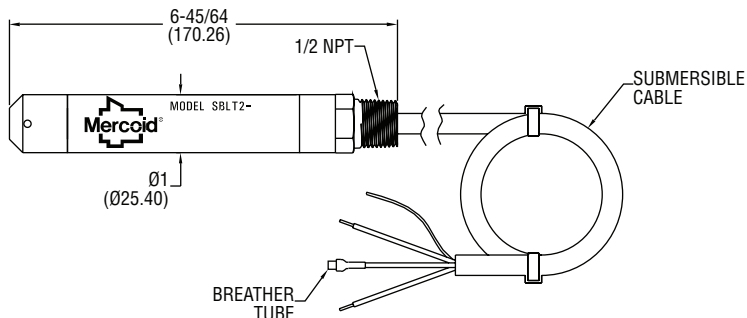

Series SBLT2 Submersible Level Transducer

Specifications - Installation and Operating Instructions



The **SBLT2 Submersible Level Transducer** is manufactured for years of trouble free service. The transmitter consists of a piezoresistive sensing element, encased in a 316 SS housing. Superior lightning and surge protection utilizing dual arrestor technology, grounded to case, eliminating both power supply surges and lightning ground strike transients (surge protection is not guaranteed and is not covered by warranty). Bullet nose design protects diaphragm from damage. Comes equipped with a 270-pound tensile strength, shielded, vented cable. Ventilation tube in the cable automatically compensates for changes in atmospheric pressure above the tank.

APPLICATIONS

- Well monitoring; Ground water monitoring; Environmental remediation; Surface water monitoring; Down hole; Water Tanks.

ELECTRICAL INSTALLATION

An external power supply delivering 13-30 VDC with minimum current capability of 40 mA DC (per transmitter) is required to power the control loop. See figure below for connection of the power supply, transmitter and receiver.

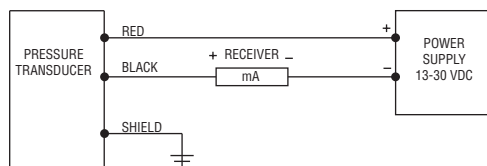

The maximum receiver load resistance (RLmax) for the DC power supply voltage (Vsup) is expressed by the formula:

$$RL_{max} = \frac{V_{sup} - 13V}{0.02A}$$

Shielded cable is recommended for control loop wiring.

SPECIFICATIONS

- Service:** Compatible liquids.
- Wetted Materials:** 316 SS, 316L SS, epoxy adhesive; Cable: Polyether polyurethane or ETFE; Bullet Nose: PVC.
- Accuracy:** ±0.25% of full scale.
- Temperature Limit:** 0 to 150°F (-18 to 66°C).
- Compensated Temperature Range:** 0 to 140°F (-18 to 60°C).
- Thermal Effect:** Less than ±0.02%/°F.
- Pressure Limit:** 2X full scale.
- Power Requirement:** 13 to 30 VDC.
- Output Signal:** 4 to 20 mA DC, 2-wire.
- Response Time:** 50 ms.
- Max. Loop Resistance:** 850 ohms at 30 VDC.
- Electrical Connections:** Wire pigtail.
- Mounting Orientation:** Suspended in tank below level being measured.
- Weight:** 2.2 lb (1.0 kg).
- Electrical Protection:** Lightning and surge protection.
- Agency Approvals:** CE.

WARNING:

A voltage potential between the ground wire of the unit and the ground of other equipment can lead to electrolytic corrosion. Always ensure the grounding system provides an equipotential between the transmitter and the earthing ground connection. Avoid using the power system protective ground since this will often have a significant potential difference to the transmitter ground. Also note that dissimilar metals in the ground system may cause electrolysis corrosion of the transmitter or other components in the ground system.

During installation, connect a voltmeter or ammeter between the shield ground wire and the grounding connection. If there is a measurable voltage or current electrolytic corrosion may be a serious possibility. If there is a potential difference then some isolation system will be required. Improper grounding may lead to damage or poor signal integrity.

Model Number Guide

Example	SBLT	20	40		SBLT2-20-40
Construction	SBLT2				Bullet style submersible level transmitter, Polyurethane cable
Range		XXX			In psi (5000 psi maximum)
Cable Length			XXX		In feet (1500 feet maximum)
Options				ETFE	ETFE cable