



Series ISDP Intrinsically Safe Differential Pressure Transmitter

Specifications - Installation and Operating Instructions



DIMENSIONS

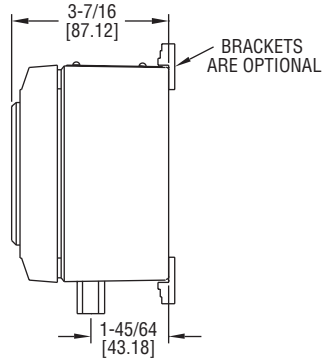
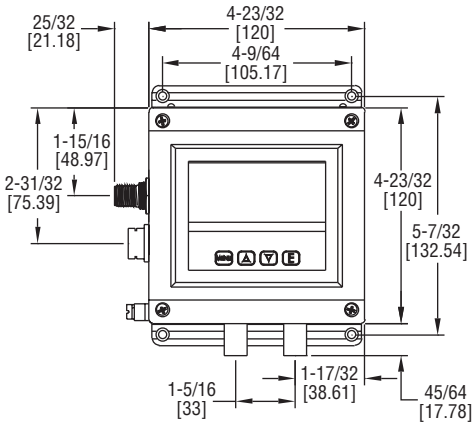

Shown with Optional A-438 Mounting Bracket

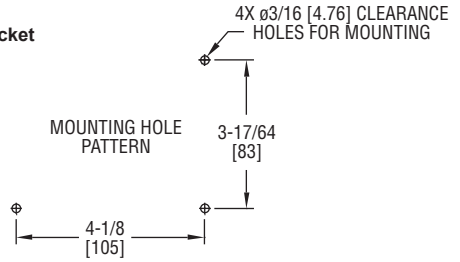
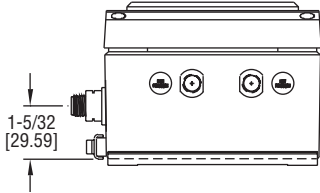

OPTIONAL A-438 BRACKET MOUNTING DIAGRAM

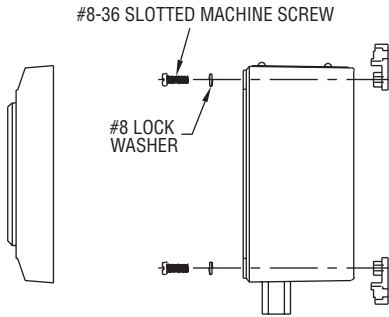

BRACKET ASSEMBLY

SPECIFICATIONS

Service: Air and non-corrosive gases.

Wetted Materials: Ranges 5" and greater: glass, PVC, silicon, alumina ceramic, epoxy, RTV, gold, aluminum, stainless steel and nickel; Ranges 1" and lower: stainless steel, silicone, gold and ceramic.

Housing Materials: Aluminum, glass.

Accuracy: $\pm 0.5\%$ at 77°F (25°C) including hysteresis and repeatability (after 1 hour warm-up).

Stability: $< \pm 1\%$ per year.

Pressure Limits: Ranges ≤ 2.5 in. w.c. = 2 psi;

5": 5 psi; 10": 5 psi; 25": 5 psi; 50": 5 psi; 100": 9 psi.

Temperature Limits: 32 to 161.6°F (0 to 72°C).

Compensated Temperature Limits: 32 to 140°F (0 to 60°C).

Thermal Effects: 0.020%/°F (0.036/°C) from 77°F (25°C).

Power Requirements: 10-35 VDC.

Output Signal: 4-20 mA DC.

Zero & Span Adjustments: Accessible via menus.

Response Time: 250 ms (dampening set to 1).

Display: 4 digit LCD 0.6" height.

Electrical Connections: M12 4 PIN Connector.

Process Connections: 1/8 female NPT.

Enclosure Rating: Designed to meet NEMA 4x (IP66).

Mounting Orientation: Mount unit in horizontal plane.

Size: 4.73" x 4.73" x 3.43" (120 mm x 120 mm x 87.1 mm).

Weight: 2 lb 10 oz (1.19 kg).

Agency Approvals: FM Approved: IS / I, II, III / 1 / ABCDEFG / T4 Ta = 0°C to 72° - 19-443480-50; ENTITY; TYPE 4X (US AND CANADA) I / 0 AEx ia / IIC / T4 Ta = 0°C to 72° - 19-443480-50; ENTITY; TYPE 4X (US) I / 0 / Ex ia / IIC / T4 Ta = 0°C to 72° - 19-443480-50; ENTITY; TYPE 4X (CANADA) CE. CENELEC EN 61326/55024: 2003; IEC 61000-4-2/3/4/6: 2001/2006/2004/2005; CENELEC EN 55011: 2006; 2004/108/EC EMC Directive.

Intrinsic Safety Information

Entity Parameters

Ui = 28VDC

Ii = 93mA

Ci = 22 nF

Li = 400 uH

Pi = 651mW

Notes:

1. Remove power from the instrument before carrying out any servicing.
2. Use only FM approved Associated Apparatus.
3. The earth terminal on the housing must be wired to a local earth ground in the hazardous area.
4. Refer to control drawing 19-443480-50, Page 15, for installation requirements.

M-12 Connector

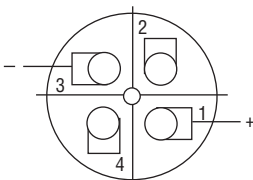

A-231 M-12 Cable Colors

PIN 1 is Brown (positive)

PIN 3 is Blue (negative)

Use Model A-231 shielded cable with 4 pin Female M-12 connection.

2-WIRE CONNECTION

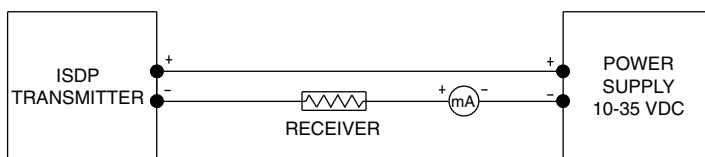

Fig. C

-----**2-Wire Operation**- An external power supply delivering 10 - 35 VDC with minimum current capability of 40 mA DC (per transmitter) must be used to power the control loop. See Fig. C for connection of the power supply, transmitter, and receiver. The range of the appropriate receiver load resistance (R_L) for the DC power supply voltage available is expressed by the formula and graph in Fig. D.

POWER SUPPLY VOLTAGE - VDC (2-WIRE CONNECTION)

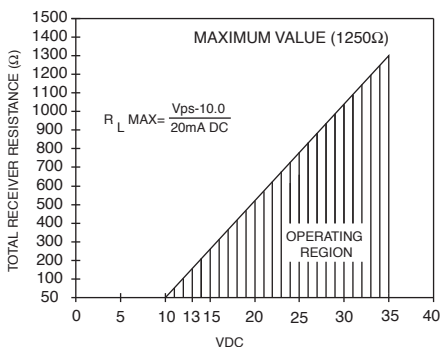

Fig. D

INSTALLATION



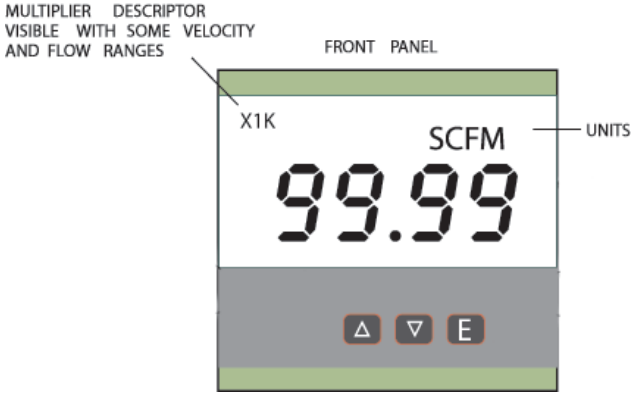

Mount the instrument in a location that will not be subject to excessive temperature, shock or vibration.

Pressure Connections

Use 1/8" male NPT fittings. When tightening fittings, grasp the brass fitting on the ISDP with a 1/2" wrench to prevent the fitting on the ISDP from turning.



KEY FUNCTIONS

	HOME POSITION FUNCTION	MAIN MENU FUNCTION	SUB MENU FUNCTION
 MENU	Allows access to the menus	Return to home position	Return to previous menu
 UP ARROW		Sequences through menus	Increments a value
 DOWN ARROW		Sequences through menus	Decrements a value
 ENTER	Displays full scale range of unit	Enter into SUB MENU	Changes a value or setting. Press ENTER and display will blink. Adjust with UP or DOWN arrows. Press ENTER to store. Display will stop blinking. Peak/Valley SUB MENU resets display to present value.

MENU MAP

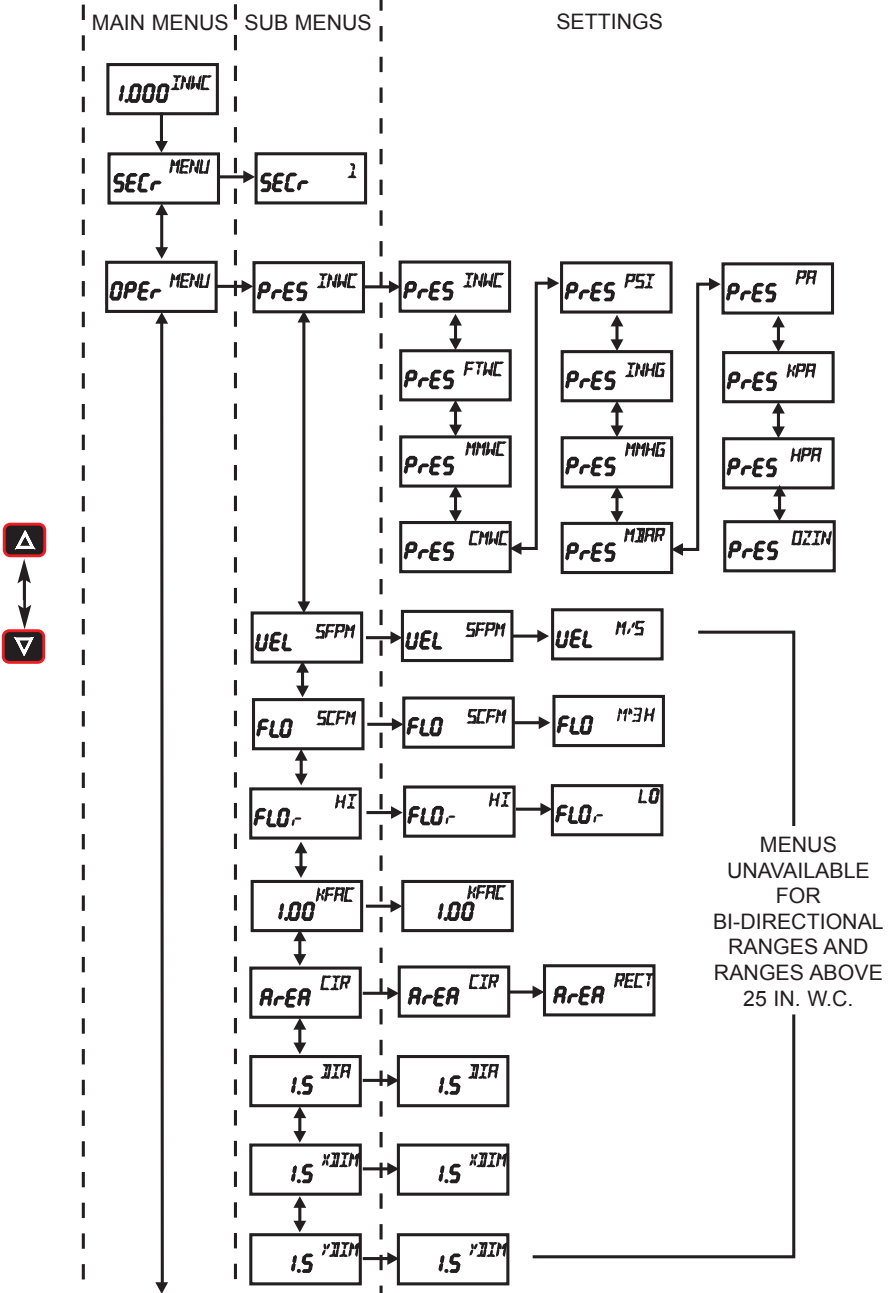

CONTINUED →

← E

← MENU

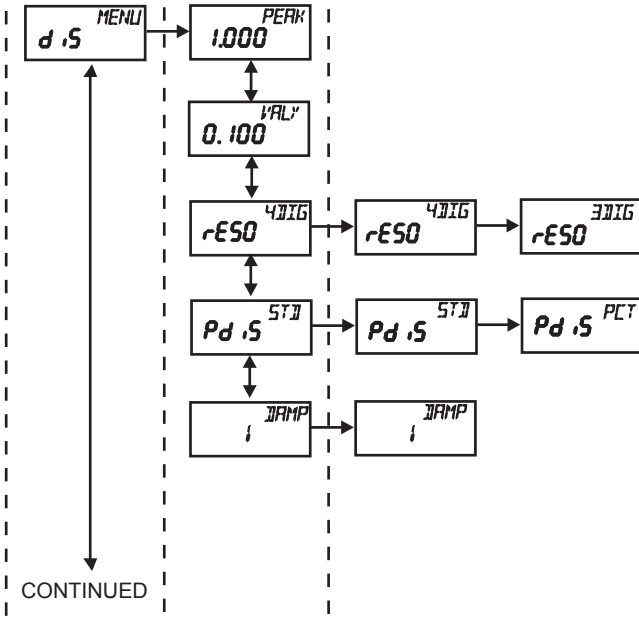

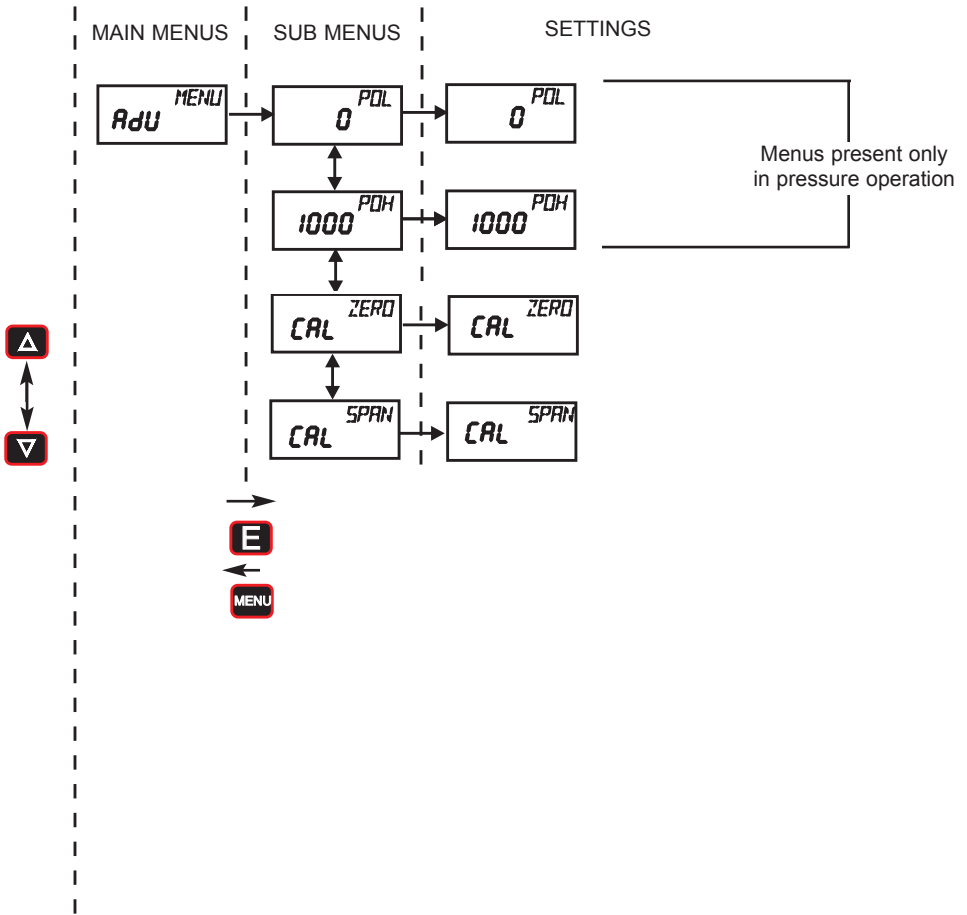

Model Chart	
Model	Range
ISDP-002	0-0.25"
ISDP-004	0-1" WC
ISDP-005	0-2.5" WC
ISDP-006	0-5" WC
ISDP-007	0-10" WC
IDSP-008	0-25" WC
ISDP-009	0-50" WC
ISDP-010	0-100" WC
ISDP-011	-0.1/+0.1" WC
ISDP-012	-0.25/+0.25" WC
ISDP-013	-0.5/+0.5" WC
ISDP-014	-1.0/+1.0" WC
ISDP-015	-2.5/+2.5" WC
ISDP-016	-5.0/+5.0" WC
ISDP-017	-10/+10" WC

Main Menu Selections (Upper Right Display Reads *MENU*)

SEC Security - Lock out access to menus and settings.

OPER Operation - Selection of Pressure, Velocity or Flow and corresponding engineering units.

DIS Display - Monitor and adjust display related settings: Peak, Valley, display resolution, % output and dampening.

ADV Advanced functions - Modify advanced function parameters, transmitter output scaling, and calibration.

MAIN MENUS and SUB MENU

SEC_r (Security) MAIN MENU

SEC_r is the only SUB MENU in the security MENU. When the security SUB MENU is selected, the present security level is displayed in the upper right hand display. To change the security level, adjust the number displayed to the number shown in the following table for the desired security level.

Security Level Displayed	Access	Password Value to Enter
1	All menus access	10
2	All settings locked	70

The password values shown in the table cannot be altered, so retain a copy of these pages for future reference.

OPE_r (Operation) MAIN MENU

The OPE_r MENU selects the measurement type of the instrument. The SUB MENUS are:

PRES - Pressure

KFAC - K Factor

XDIM - X Dimension

VEL - Velocity

AREA - Area

YDIM - Y Dimension

FLO - Flow

DIA - Diameter

If the instrument is set for Velocity, the OPE_r MENU will have an additional *KFAC* SUB MENU. If the instrument is set for Flow, the OPE_r MENU will have additional *KFAC* and *AREA* SUB MENUS. These will be discussed under Velocity and Flow. When scrolling through the OPE_r SUB MENUS, the measurement type the unit is currently set for will show the units in the upper right display. The other measurement types will have a blank upper right display.

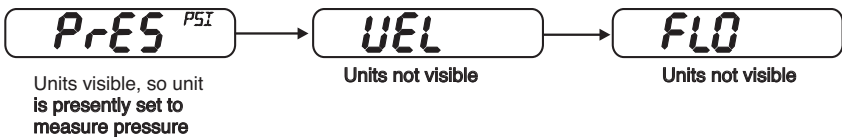

PRES (Pressure) SUB MENU

For pressure measurement, the following units are available:

INWC - Inches of water column

FTWC - Feet of water column

MMWC - Millimeters of water column

CMWC - Centimeters of water column

PSI - Pounds per square inch

INHG - Inches of mercury

MMHG - Millimeters of mercury

MBAR - Millibar

PA - Pascal

KPA - Kilopascals

HPA - Hectopascals

OZIN - Ounce inches

Table 1 Pressure Range vs. Available Units

INWC	FTWC	MMWC	CMWC	PSI	INHG	MMHG	MBAR	PA	KPA	HPA	OZIN
.1000		2.540	.2540			.1868	.2491	24.91		.2491	
.2500		6.350	.6350			.4671	.6227	62.27		.6227	.1445
.5000		12.70	1.270			.9342	1.245	124.5	.1245	1.245	.2890
1.000		25.40	2.540			1.868	2.491	249.1	.2491	2.491	.5780
2.500	.2083	63.50	6.350		.1839	4.671	6.227	622.7	.6227	6.227	1.445
5.000	.4167	127.0	12.70	.1806	.3678	9.342	12.45	1245	1.245	12.45	2.890
10.00	.8333	254.0	25.40	.3613	.7356	18.68	24.91	2491	2.491	24.91	5.780
25.00	2.083	635.0	63.50	.9032	1.839	46.71	62.27	6227	6.227	62.27	14.45
50.00	4.167	1270	127.0	1.806	3.678	93.42	124.5		12.45	124.5	28.90
100.0	8.333	2540	254.0	3.613	7.356	186.8	249.1		24.91	249.1	57.80

NOTE: *OVFL* (over flow) or *UF* (under flow) will appear when the ranges have been exceeded above or below full scale by 2%.

VEL (Velocity) SUB MENU

For velocity measurement, the following units are available:

SFPM - Standard feet per minute

M/S - Meters per second

Table 2 Available Velocity Ranges

INPUT RANGE INWC	SFPM RANGE	M/S RANGE
0 - 0.1	0 - 1266	0 - 6.431
0 - 0.25	0 - 2002	0 - 10.17
0 - 0.5	0 - 2832	0 - 14.39
0 - 1	0 - 4004	0 - 20.35
0 - 2.5	0 - 6332	0 - 32.17
0 - 5	0 - 8954	0 - 45.48
0 - 10	0 - 12.66 x IK	0 - 64.33
0 - 25	0 - 20.02 x IK	0 - 101.7

NOTE: Air velocity and flow readings are based upon standard dry air conditions with an ambient temperature of 70°F and a barometric pressure of 29.92 INHG.

FLO (Flow) SUB MENU

For flow measurements the following units are available:

SCFM - Standard cubic feet per minute

M³H - Cubic meters per hour

FLOr (Flow Range) SUB MENU

LO - 99.99 x 1K flow range

HI - 999.9 x 1K flow range

Tables 3 -6 show the flow ranges available, and the maximum duct size that can be set for each input range.

Table 3

FLOr = LO Maximum Duct Size (English)

RANGE IN WC	SCFM RANGE	MAX. DUCT SIZE, SQ. FT.
0.1	99.99 x 1K	78.9
0.25	99.99 x 1K	49.9
0.5	99.99 x 1K	35.3
1	99.99 x 1K	24.9
2.5	99.99 x 1K	15.7
5	99.99 x 1K	11.1
10	99.99 x 1K	7.8
25	99.99 x 1K	4.9

Table 4

FLOr = HI Maximum Duct Size (English)

RANGE IN WC	SCFM RANGE	MAX. DUCT SIZE, SQ. FT.
0.1	999.9 x 1K	789.8
0.25	999.9 x 1K	499.5
0.5	999.9 x 1K	353.1
1	999.9 x 1K	249.7
2.5	999.9 x 1K	157.9
5	999.9 x 1K	111.7
10	999.9 x 1K	78.9
25	999.9 x 1K	49.9

Table 5

FLOr = LO Maximum Duct Size (Metric)

RANGE IN WC	M ³ /Hr RANGE	MAX. DUCT SIZE M ²
0.1	99.99 x 1K	4.32
0.25	99.99 x 1K	2.73
0.5	99.99 x 1K	1.93
1	99.99 x 1K	1.37
2.5	99.99 x 1K	0.86
5	99.99 x 1K	0.61
10	99.99 x 1K	0.43
25	99.99 x 1K	0.27

Table 6

FLOr = HI Maximum Duct Size (Metric)

RANGE IN WC	M ³ /Hr Range	MAX. DUCT SIZE, M ²
0.1	999.9 x 1K	43.19
0.25	999.9 x 1K	27.31
0.5	999.9 x 1K	19.3
1	999.9 x 1K	13.64
2.5	999.9 x 1K	8.63
5	999.9 x 1K	6.10
10	999.9 x 1K	4.31
25	999.9 x 1K	2.73

KFAC SUB MENU

KFAC K Factor - becomes accessible if the instrument is set for Velocity or Flow. When the Digihelic® II Controller is used with a Pitot tube, the manufacturer may specify a K Factor. The adjustment range is 0.01 to 2.00. The factory setting is 1.

AREA, DIA, XDIM and YDIM SUB MENUS

These SUB MENUS become accessible if the instrument is set for flow. When measuring flow, the area of the duct must be specified. Tables 3 and 4 show the input range vs maximum flow and duct size. For a rectangular duct the maximum size is specified in square feet or meters. For a circular duct the maximum size is specified as the diameter. X, Y and circular dimensions are entered in feet with 0.01 foot resolution for $FLO = LO$ and 0.1 foot resolution for $FLO = HI$, or entered in millimeters with 1 millimeter resolution.

AREA - Area, select *CIR* for a circular duct or *RECT* for a rectangular duct. If a circular duct is selected, the *DIA* SUB MENU will be activated. If a rectangular duct is selected, the *XDIM* and *YDIM* SUB MENUS will be activated.

DIA - Diameter, enter the diameter of a duct
XDIM - Enter the "X" dimension of a duct
YDIM - Enter the "Y" dimension of a duct

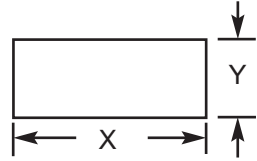

d.S (Display) MAIN MENU

<i>PEAK</i> - Peak value	<i>RESO</i> - Resolution
<i>VAL_y</i> - Valley value	<i>Pd.S</i> - Process display
<i>ZERO</i> - Zero	<i>DAMP</i> - Dampening level

PEAK (Peak) SUB MENU

The Peak feature stores the highest pressure reading the instrument has measured since the last reset or power up. At power up *PEAK* is reset to the present pressure reading. To manually reset the *PEAK* value, press the ENTER key while in the *PEAK* SUB MENU.

VAL_y (Valley) SUB MENU

The valley feature stores the lowest pressure reading the instrument has measured since the last reset or power up. At power up *VAL_y* is reset to the present pressure reading. To manually reset the *VAL_y* value, press the ENTER key while in the *VAL_y* SUB MENU.

rESD (Resolution) SUB MENU

The Series ISDP Controller is capable of displaying four digits of resolution.

However, at very low pressures the instability of the pressure may cause fluctuations in the least significant digit causing the least significant digit to be of little value.

Three digit resolution (*3DIG*) can only be active when there is at least one digit to the right of a decimal.

3DIG - Set display for 3 digit resolution

4DIG - Set display for 4 digit resolution

PdS (Process Display) SUB MENU

STD - Display reads pressure, velocity, or flow values

PCT - Display reads % of full scale value

When the display is reading percent, *PCT* is displayed in the upper right of the display. The percent display is only available in pressure operation.

DAMP (Dampening) SUB MENU

Adjust from 1-16

Dampening stabilizes the display from instabilities due to things such as vibration and excessive pressure fluctuations. The dampening setting adjusts the amount of readings that are averaged for each display update. Adjust the dampening value until the display reads a stable value for the application.

PdU (Advanced) MAIN MENU

POL - Process output low

POH - Process output high

ZERO - Zero calibration

SPAN - Span calibration

POL and POH (Process Output Low and High) SUB MENUS

This feature is used in pressure operation only.

Process output low and high are used to scale the 4-20 mA output. Set *POL* to the desired display reading for 4mA output, and set *POH* to the desired display reading for 20 mA output. *POH* must be higher than *POL*. *POL* may be adjusted 2% BELOW minimum scale up to *POH*. *POH* may be adjusted from *POL* to 2% ABOVE maximum scale.

ZERO and SPAN (Calibration of Zero and Span) SUB MENUS

The lower display reads *CAL* in this mode.

ZERO Calibration

NOTE: For accurate calibration, DO NOT apply any pressure when performing this function.

With the display reading *ZERO*, press the ENTER key. The upper display will blink. Press ENTER again to complete the zeroing of the instrument or press the *MENU* key to cancel.

SPAN Calibration

With the display set to *SPAN*, apply full scale pressure to the unit. Press the ENTER key. The upper display will blink. Press ENTER again to complete the calibration or press the *MENU* key to cancel.

Maintenance

Upon final installation of the Series ISDP intrinsically Safe Differential Pressure Transmitter, no routine maintenance is required. The Series ISDP is not field serviceable and should not be returned if repair is needed (field repair should not be attempted and may void warranty). Be sure to include a brief description of the problem plus any relevant application notes. Contact customer service to receive a return goods authorization number before shipping.

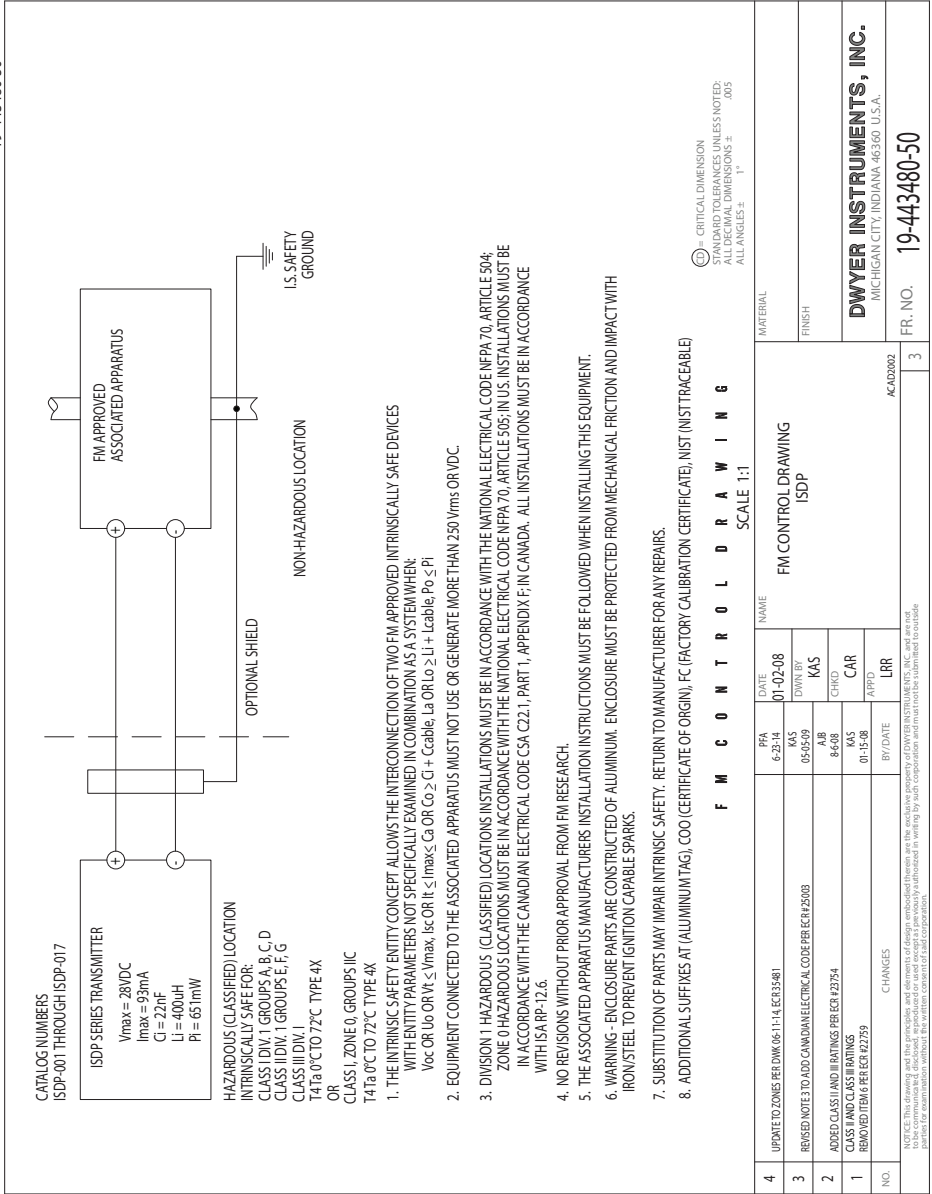

CRITICAL DIMENSION
 STANDARD TOLERANCES UNLESS NOTED:
 ALL DECIMAL DIMENSIONS ± .005
 ALL ANGLES ± 1°

Dwyer Instruments, Inc.
 MICHIGAN CITY, INDIANA 46360 U.S.A.

FR. NO. 19-443480-50

ACAD0002 3

F M C O N T R O L D R A W I N G
 SCALE 1:1

FM CONTROL DRAWING
 ISDP

NO.	DATE	DATE	DATE	DATE
4	01-02-08	01-02-08	01-02-08	01-02-08
3	05-05-09	05-05-09	05-05-09	05-05-09
2	08-08-08	08-08-08	08-08-08	08-08-08
1	01-15-08	01-15-08	01-15-08	01-15-08
NO.				

UPDATES TO ZONE: PER DWK 06-11-14 EC835481

REVISED NOTES TO ADD CANADIAN ELECTRICAL CODE PER EC IN 2008

ADDED CLASS I AND II RATINGS PER COR 23534

ADDED I AND II RATINGS PER COR 23534

ADDED I AND II RATINGS PER COR 23534

ADDED I AND II RATINGS PER COR 23534

ADDED I AND II RATINGS PER COR 23534

ADDED I AND II RATINGS PER COR 23534

NOTE: This drawing and the principles and elements of design embodied therein are the exclusive property of DWYER INSTRUMENTS, INC. and are not to be reproduced, stored in a retrieval system, or transmitted in any form or by any means, electronic, mechanical, photocopying, recording, or by any information storage and retrieval system, without the written consent of Dwyer Instruments, Inc.