

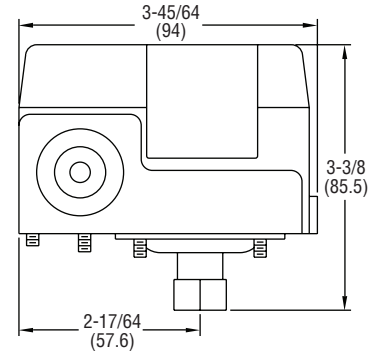

Series CXA Water Pump Pressure Switch

Specifications - Installation and Operating Instructions

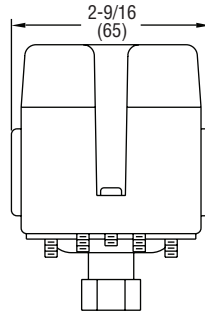
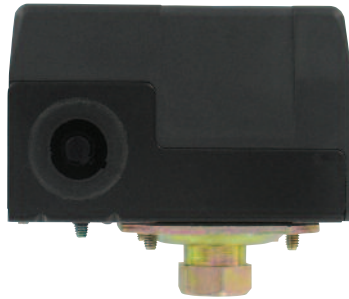

The Series CXA Water Pump Pressure Switches have been proven reliable for controlling automatic water systems. These switches are very popular for use on water well pumps and pumping systems. The set point and deadband are both easily adjustable via screws inside the cover. For ease of installation, the switches come with a 1/4" female NPT process connection and can be mounted in any orientation. The series CXA's simple design makes it a great switch for an installer at any skill level.

SPECIFICATIONS

- Service:** Compatible liquids and gases.
- Wetted Materials:** Silicone, steel, and SS.
- Temperature Limits:** 140°F (60°C).
- Pressure Limits:** See model chart.
- Enclosure Rating:** General purpose.
- Repeatability:** ±5 psig (±0.3 bar).
- Switch Type:** DPST snap action (see model chart).
- Electrical Ratings:** 20A @ 120 VAC, 12A @ 240 VAC, 9.6A @ 240 VAC (3 phase), 8.6A @ 32 VDC, 3.1A @ 120 VDC, 1.6A @ 240 VDC.
- Electrical Connections:** Screw terminal.
- Conduit Connection:** 7/8" hole for 1/2" conduit hub (2 places).
- Process Connection:** 1/4" female NPT.
- Mounting Orientation:** Switch can be installed in any position.
- Setpoint Adjustment:** Internal screws.
- Weight:** 0.75 lb (0.34 kg).
- Deadband:** See model chart.
- Agency Approvals:** CE, UL pending.

Model	Switch Type	Range psig (bar)	Approx. Adjustable Deadband psig (bar)	Max. Pressure psig (bar)
CXA-S1	NC	15-80 (1.0-5.5)	15-30 (1.0-2.1)	129 (8.9)
CXA-S2	NC	30-100 (2.1-6.9)	20-35 (1.4-2.4)	179 (12.3)
CXA-S3	NC	35-150 (2.4-10.3)	30-40 (2.1-2.8)	204 (14.1)
CXA-R1	NO	15-80 (1.0-5.5)	15-30 (1.0-2.1)	129 (8.9)
CXA-R2	NO	30-100 (2.1-6.9)	20-35 (1.4-2.4)	179 (12.3)
CXA-R3	NO	35-150 (2.4-10.3)	30-40 (2.1-2.8)	204 (14.1)

INSTALLATION/MOUNTING

The switch can be pipe mounted in any position. Do not twist the case when installing. Use a wrench on the pressure connection flats.

WIRING

All wiring must conform to the National Electrical Code and local regulations. Do not install the control to handle loads in excess of electrical rating shown in specifications or as indicated on instructions inside control cover.

CAUTION: No lubrication or periodic servicing is required. Mount the control securely. Never exceed the electrical rating for the switch. Use the control only with compatible medias.

MAINTENANCE

Upon final installation of the Series CXA Water Pump Pressure Switch, no routine maintenance is required. A periodic check of the system calibration is recommended. The Series CXA is not field serviceable and should be returned if repair is needed (field repair should not be attempted and may void warranty). Be sure to include a brief description of the problem plus any relevant application notes. Contact customer service to receive a return good authorization number before shipping.

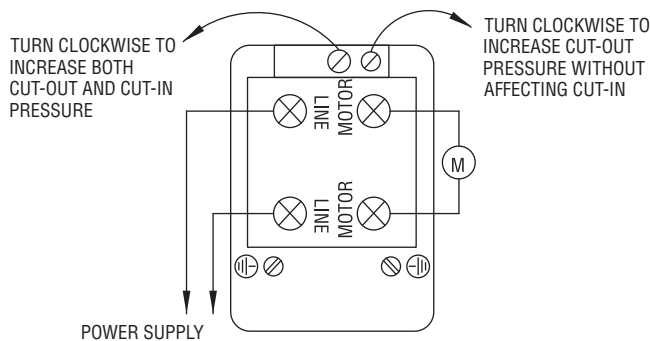

WIRING DIAGRAM