

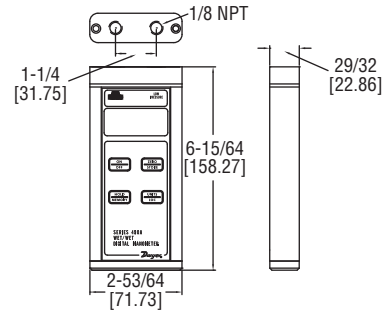

Series 490A Wet/Wet Handheld Digital Manometer

Specifications - Installation & Operating Instructions



Series 490A Digital Manometers are versatile, hand-held, battery operated manometers available in several basic ranges for positive or positive differential pressure measurement and can tolerate most liquid media compatible with 316LSS. A memory function allows storage of up to 40 readings for later recall and a backlight provides auxiliary lighting for hard-to-see locations. Standard are a hold feature and both visual and audible overpressure alarms. A new feature added to the Series 490A is a field adjustable damping. This allows the user to choose the level of display averaging rate corresponding to the fluctuation level common in many applications. A 9 V alkaline battery is included that provides up to 100 hours of operation.

BATTERY INSTALLATION

The unit is shipped with a separate 9 volt alkaline battery which must be installed before operation. Remove the two screws holding the bottom endcap in place and remove the endcap. Connect the battery to the enclosed battery clip, making sure to observe correct polarity. Be careful not to trap wires between the battery, case, or foam pads which retain the battery. This could make it difficult to install the battery or remove it later for replacement. Be sure that the rubber gasket is properly seated in the gasket channel of the endcap and replace endcap. Note that the endcap will only fit one way because the holes are slightly off-center. Place the Z shaped wrist strap clip in one of the screw recesses and replace the screws. Do not over tighten the screws. Attach the wrist strap to the clip.

When battery replacement becomes necessary, use only a 9 volt alkaline type such as a Duracell® MN 1604, Eveready® 522, or equivalent. Zinc-carbon types, often labeled heavy-duty are not recommended because of the increased potential for leakage. Alkaline batteries are also a better value because they last up to three times longer in this device.

Low Battery Indicator

A weak battery can cause improper operation or inaccurate measurements. A low battery indicator is provided on the display to show when the battery needs replacement.

NOTICE

Although the unit might appear to function and indicate properly, the accuracy of readings cannot be guaranteed when the LOW BAT indicator is illuminated. Replace the battery with a new one. Do not leave an exhausted battery in the unit due to potential leakage.

ON-OFF OPERATION

The on-off control is a toggle function. Press and release the ON/OFF button once to turn the unit on and press it again to turn it off. If the manometer is left on with no activity for approximately 20 minutes, the unit will turn itself off to conserve the battery.

Model	English Range	Metric Range	Maximum Pressure	Available Engineering Units
490A-1	0 to 15 psi	0 to 103.4 kPa	30 psi (2.7 bar)	psi, in w.c., in Hg, cm w.c., mm Hg, kPa, hPa, mbar, bar, oz/in ²
490A-2	0 to 30 psi	0 to 206.9 kPa	60 psi (4.13 bar)	psi, in w.c., in Hg, cm w.c., mm Hg, kPa, hPa, mbar, bar, oz/in ²
490A-3	0 to 50 psi	0 to 344.8 kPa	100 psi (6.89 bar)	psi, in w.c., in Hg, cm w.c., mm Hg, kPa, hPa, mbar, bar, oz/in ²
490A-4	0 to 100 psi	0 to 689.5 kPa	200 psi (13.78 bar)	psi, in w.c., in Hg, cm w.c., mm Hg, kPa, hPa, mbar, bar, oz/in ²
490A-5	0 to 500 psi	0 to 3448 kPa	1000 psi (68.9 bar)	psi, in Hg, kPa, bar
490A-6	0 to 200 psi	0 to 1379 kPa	400 psi (27.57 bar)	psi, in w.c., in Hg, kPa, bar

SPECIFICATIONS

Service: Compatible gases & liquids.

Wetted Materials: 316 SS.

Accuracy: ±0.5% FS from 60 to 78°F (15.6 to 25.6°C); ±1.5% FS from 32 to 60°F and 78 to 104°F (0 to 15.6°C and 25.6 to 40°C).

Pressure Hysteresis: ±0.1% FS.

Pressure Limits: See chart

Temperature Limits: Operating: 0 to 140°F (-17.8 to 60°C); Storage: -4 to 176°F (-20 to 80°C).

Display: 4-digit LCD (.425" H x .234" W digits).

Resolution: See chart.

Process Connections: Two 1/8" (3.18 mm) female NPT.

Power Requirements: 9 V alkaline battery, installed non-functional, user replaceable.

Weight: 14.1 oz (400 g).

Agency Approvals: CE.

ZEROING PRESSURE READING

Potential inaccuracy due to temperature effects can be minimized by re-zeroing immediately before use. To zero the display, vent both ports to the atmosphere so no pressure is applied to either port. Press the ZERO/STORE button and ---- will be momentarily displayed as zeroing occurs. Zeroing is not possible when the memory mode is in use. It must be done before selecting that function.

If the unit is accidentally zeroed with pressure applied to one of the ports, the pressure reading might display incorrectly. To correct, vent the pressure ports to atmosphere and press the ZERO/STORE button to zero the unit.

BACKLIGHT

The Model 490A includes a display backlight to allow use in the dark or in poor lighting conditions. The manometer must be switched off before this feature can be activated. Next, press and hold the ON/OFF button. After about one second, the backlight will come on and remain lighted for approximately 2 minutes after which it will turn itself off to conserve battery life.

PRESSURE CONNECTION

Measuring Single Pressure

To measure single positive pressure, connect the tubing to the port marked "High Pressure" and vent the opposite port to the atmosphere.

Measuring Differential Pressure

To measure differential pressure, connect the higher positive pressure to the port marked "High Pressure" and the lower positive pressure to the port marked "Low Pressure". The manometer will indicate the difference between the two.

Overpressure Alarm

A visual indicator and audible alarm are provided to alert the user that pressure has exceeded the operating range of the unit. Exceeding the range will not damage it or affect calibration as long as the maximum rated pressure is not exceeded. The maximum pressure for all units is shown on the rear label and on page 1 of these instructions.

CAUTION Do not exceed the maximum rated pressure of the manometer. Doing so will cause permanent damage to the sensor, may rupture the housing, and/or cause personal injury.

SELECTING PRESSURE UNITS

Up to seven pressure units are available. The display will indicate the current selection. To change to different units, use the UNITS/LOC button. Each press of the button will cause an advance to the next choice. The selected units will remain in the memory even when the power is shut off. This way, the user preferences will always be displayed after the initial selection.

DISPLAY HOLD

In situations where a reading needs to be temporarily retained, the Model 490A includes a display hold feature which freezes the current reading and holds it on the display until it is cleared. To activate this operation, press the HOLD/MEMORY button when the desired pressure is displayed. A HOLD indicator will appear on the display to indicate that the reading shown is frozen. To return to normal operation, press the HOLD/MEMORY button again. The HOLD indicator will disappear and the current pressure will be shown.

MEMORY FUNCTION

A memory function is included in the Model 490A that allows users to store up to 40 pressure readings for later review or recording. The readings are stored in non-volatile memory so they will be retained even if the unit is shut off or the battery is removed.

Storing Pressure Readings

To store a reading, press and hold the HOLD/MEMORY button until ST01 displayed. Next, press the ZERO/STORE button to save the current reading to the ST01 memory location. A beep will sound indicating that the reading has been saved. As each reading is saved, the memory location display will advance to the next number. To resume pressure measurement, press the HOLD/MEMORY button again. Note that in the memory mode, the display zero function is not available. To zero the display, exit the memory mode and then press the ZERO/STORE button.

Viewing Stored Readings – Selecting a Location

To view the contents of the memory, press and hold the HOLD/MEMORY button until RD01 is displayed. Next, press UNITS/LOC to view other memory locations. To resume pressure measurement, press the HOLD/MEMORY button again.

Clearing Memory

To clear the contents of the memory, press and hold the HOLD/MEMORY button until CLR is displayed. Next, press the ZERO/STORE button to clear all previously stored readings. During this operation --- will be displayed. Once the memory is cleared, the current pressure will be displayed.

Exiting Memory Mode

To exit the memory mode, press the HOLD/MEMORY button again and the unit will return to normal operation.

DAMPENING FUNCTION

The dampening feature allows users to enter a dampening number from 1 to 16 (default value = 2). Entering a larger number increases the amount of readings that are averaged for each display update.

In order to access the dampening feature:

1. Press and hold the HOLD/MEMORY button until DAMP is displayed.
2. Once DAMP is selected, a number is shown in the upper right portion of the LCD, along with the current pressure reading. This number is the dampening number. Adjust the number up by pressing the ZERO/STORE button or down by pressing the UNITS/LOC button. The LCD update rate slows as the number increases from 1 to 16. Therefore, for best results, choose the smallest number that provides a stable pressure reading.
3. Once the pressure reading is stable, press the HOLD/MEMORY button to store the dampening value.

OPTIONAL 3-WAY VALVE

For certain hydronic applications, it is beneficial to measure the differential pressure with the assistance of the optional attached 3-way valve. (See Fig. A)

Begin with valve V1 open and valves V2 and V3 closed. (See Fig. B) Slowly open V2 and V3. Once the pressure has stabilized and is equal on the high and low side, V1 can be closed and normal operation can proceed. To ensure proper pressures will be detected by the 490A, use the bleed fitting provided with this valve package. (See Fig. A) Before applying pressure to the process connections, turn V1 to the open position and back off the bleed screw. Next apply pressure. After the flowing liquid is free of bubbles, retighten the bleed screw. Before taking the 490A offline from the process, open V1 then close V2 and V3.

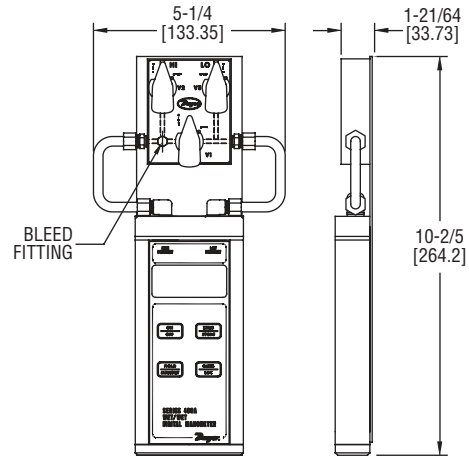

Figure A

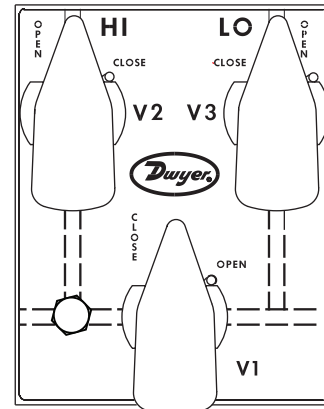

Figure B

MAINTENANCE/REPAIR

Upon final installation of the Series 490A, no routine maintenance is required. The Series 490A is not field serviceable and should be returned if repair is needed. Field repair should not be attempted and may void warranty.

WARRANTY/RETURN

Refer to "Terms and Conditions of Sale" in our catalog and on our website. Contact customer service to receive a Return Goods Authorization Number before shipping the product back for repair. Be sure to include a brief description of the problem plus any additional application notes.

Duracell® is a registered trademark of The Gillette Company
Eveready® is a registered trademark of The Eveready Battery Company, Inc.