

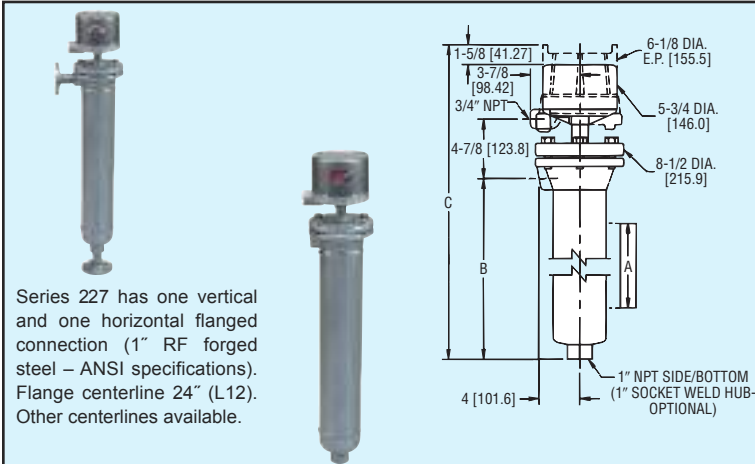

Series
225

Flanged Chamber

Adjustable Deadband 12" to 24", Pressure to 1000 psig (68.9 bar),
Temperature to 475°F (246°C), Hermetically Sealed Switches



Operation Section

Type	*Suffix Number	Adjustable Level Change Dimension "A"	Chamber Dimension "B"	Overall Control Dimension "C"
225---- G, WT	L12	12" max (305 mm)	2-1/2" min (63.5 mm)	21-1/16" (535 mm)
	L24	24" max (610 mm)	2-1/2" min (63.5 mm)	33-1/16" (840 mm)
225---- E, EV	L12	12" max (305 mm)	2-1/2" min (63.5 mm)	21-1/16" (535 mm)
	L24	24" max (610 mm)	2-1/2" min (63.5 mm)	33-1/16" (840 mm)

*Consult factory for longer lengths. Adjustable 12" differential is standard.

Minimum differential is based on a specific gravity of 1.0 and may vary by type of control and specific gravity of liquid used.

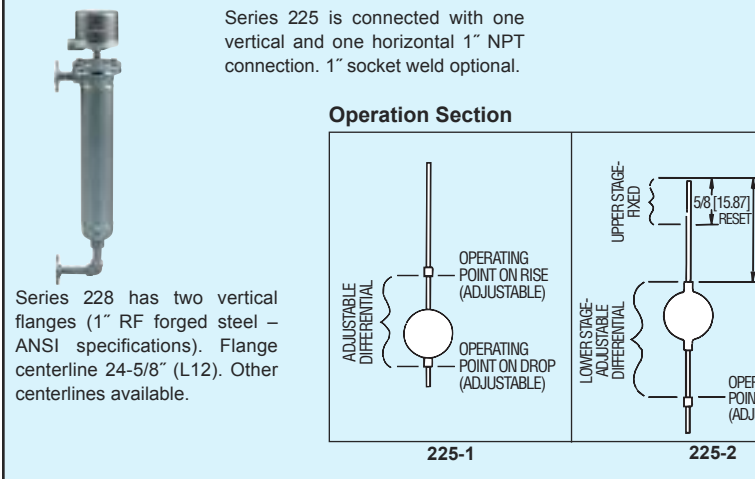

Adjustable deadband, flanged chamber and side mount are featured in the heavy duty reliable 225 series. A choice of four operating styles are offered: 1. Single stage adjustable deadband suitable for pump operation; 2. Two stage operation with adjustable lower stage, fixed upper stage for pump and high alarm; 3. Fixed lower stage and adjustable upper stage for pump and low alarm; 4. Fixed upper and lower stage for high and low alarm. Alarm stages can also be used for shutdown. Adjustable level changes are available in increments of 12", 24", 36", and 48".

APPLICATIONS

Oil refineries, chemical plants, power generating stations, pumping stations, heat transfer systems, sanitary/waste water facilities, drip legs, hydraulic systems, boilers.

SPECIFICATIONS

Minimum Specific Gravity: 0.75.

Switch Type: Snap action or mercury. See charts A and B.

Electrical Ratings: See charts A and B.

Wiring Connections:

G, WT or E enclosure, terminal block;

EV enclosure, 18" (460 mm) leads.

Process Connections: 1" NPT standard (1" socket weld hubs or flanges optional).

Enclosure Rating: See model chart.

Enclosure:

G, painted steel and aluminum;

WT, painted steel, aluminum, neoprene;

E, aluminum. EV, aluminum and neoprene.

Wetted Parts: C1 construction. Chamber, carbon steel. Float and trim 303SS, 304SS, 430SS.

Weight: 225, 50 lb (22.7 kg); 227, 60 lb (27 kg); 228, 67 lb (30.4 kg).

Agency Approvals: UL.

Suggested Specifications

Liquid level control shall be 225 (227) (228) Series with adjustable deadband of (12") (24") (36") (48"). Unit shall be external side mount type. Process connections shall be 1" NPT (socket weld hub) (flanged). Suitable for operation at 1000 psig (68.9 bar) at 100°F (38°C); 850 psig (21 bar) at 475°F (246°C) with a minimum specific gravity of 0.75. Switch mechanism shall be gravity return and shall be activated by a stainless steel float.

Model Chart - Series 225

Example	225-2	WT	7810	10	C1	75		L12	225-2-WT-7810-10-C1-75-L12 Liquid level control, flanged carbon steel chamber. Weatherproof enclosure. Two single pole double throw snap action switches. Lower stage adjustable deadband to operate pump or other devices, upper stage fixed to operate alarm or shutdown. Operating pressure 600 psig (41.3 bar) at 100°F (38°C) 550 psi (37.9 bar) at 475°F (246°C). Side/bottom process connection, 1" NPT. Minimum specific gravity 0.75.		
Operation	225-1 225-2 225-3 225-4		XXXX XXXX XXXX XXXX			XX XX XX			Single stage operation with an adjustable deadband. Suitable for pump operation. Two stage operation. Lower stage has adjustable deadband. Upper stage has fixed deadband. Suitable for pump and high alarm. Two stage operation. Lower stage fixed deadband. Upper stage has adjustable deadband. Suitable for pump and low alarm. Two stage operation. Both stages have fixed deadband with adjustable spread between stages. Suitable for high and low alarm or shutdown.	UL UL UL UL	
Enclosures		G WT E EV							General purpose, NEMA-1. Weatherproof NEMA-3R, 4, 4X. Explosion-proof NEMA-7, 9. Class I Groups B, C, D. Class II Groups E, F, G. Explosion-proof, vapor-proof NEMA-7, 9. Class I Groups B, C, D. Class II Groups E, F, G.	UL UL UL UL	
Circuits (For electrical circuits see charts A & B below)			48XX 48XX 78XX 78XX 78XXHM 98XX 98XX			XX XX XX			Single stage. Mercury switch. See chart A. Two stage. Mercury switch. See chart A. Single stage. Snap switch. See chart B. Two stage. Snap switch. See chart B. Hermetically sealed snap switch. See chart B. Single stage. High capacity DC snap switch. Use heat fins (HF) if process temperature exceeds 350°F (177°C). Do not exceed 450°F (232°C). See chart B. Two stage. High capacity DC snap switch. Use heat fins (HF) if process temperature exceeds 350°F (177°C). Do not exceed 450°F (232°C). See chart B.		
Flanged Chamber Construction 1" NPT/HUBS	225				C1 C1 C1	75 75 80			Carbon steel body. Minimum specific gravity 0.75. Side/bottom process connections. 1" NPT hub. Pressure rating 600 psi (41.3 bar) at 100°F (38°C), 550 psi (37.9 bar) at 475°F (246°C). Minimum specific gravity 0.80. Side/bottom process connections. 1" NPT hub. Pressure rating 1000 psi (68.9 bar) at 100°F (38°C), 850 psi (58.6 bar) at 475°F (246°C).	UL UL UL UL	
Flanged Chamber Construction 1" NPT/HUBS	227 227 227 227 227 227 228 228 228 228 228 228				C1 C1 C1 C1 C1 C1 C1 C1 C1 C1 C1 C1	175 375 75 180 380 680 175 375 75 180 380 680			1" 150# flanges side/bottom process connections. Minimum specific gravity 0.75. 1" 300# flanges side/bottom process connections. Minimum specific gravity 0.75. 1" 600# flanges side/bottom process connections. Minimum specific gravity 0.75. 1" 150# flanges side/bottom process connections. Minimum specific gravity 0.80. 1" 300# flanges side/bottom process connections. Minimum specific gravity 0.80. 1" 150# flanges side/side process connections. Minimum specific gravity 0.75. 1" 300# flanges side/side process connections. Minimum specific gravity 0.75. 1" 600# flanges side/side process connections. Minimum specific gravity 0.75. 1" 150# flanges side/side process connections. Minimum specific gravity 0.80. 1" 300# flanges side/side process connections. Minimum specific gravity 0.80. 1" 300# flanges side/side process connections. Minimum specific gravity 0.80.	UL UL UL UL UL UL UL UL UL UL UL UL	
Adjustable Level								L12 L24	2-1/2" (63.5 mm) minimum, 12" (305 mm) maximum. 2-1/2" (63.5 mm) minimum, 24" (610 mm) maximum. Consult factory for longer lengths.		
Options								H2	1" socket weld hub instead of 1" NPT.		

Charts A & B - Electrical Circuits and Ratings

Switch Type	Switch Action	Electrical Ratings in AMPS					Ordering Code			UL	Order Code
		AC		DC			Single Stage	Two Stage			
		120V	240V	440V	125V	250V		Lower	Upper		
Chart A Mercury Contacts	SP-ST Open on level FALL	10	5	3†	10	5	-4821	-4821	-21	UL	
	SP-ST Open on level RISE	10	5	3†	10	5	-4820	-4820	-20	UL	
	SP-DT One switch	4	2	1†	4	2	-4810	-4810	-10	UL	
	SP-DT Two switches E.I.*	10	5	3†	10	5	-4815	-4815	-15	UL	
	DP-ST Two switches E.I.* Open on level FALL	10	5	3†	10	5	-4813	-4813	-13	UL	
	DP-ST Two switches E.I.* Open on level RISE	10	5	3†	10	5	-4814	-4814	-14	UL	
	DP-DT Two SPDT switches	4	2	1†	4	2	-4806	-4806	-06	UL	
Chart B Snap Action Contacts	SP-DT One switch	12	5	3†	0.5**	0.25**	-7810	-7810	-10	UL	
	DP-DT Two SPDT switches	12	5	3†	0.5**	0.25**	-7806	-7806	-06	UL	
	SP-DT One hermetically sealed SPDT switch	5	5				-7810HM	-7810HM	-10HM		
	DP-DT Two hermetically sealed SPDT switches	5	5				-7806HM	-7806HM	-06HM		
	DP-DT Two SPDT switches	10	3		10‡	3‡	-9806	-9806	-06		
	SP-DT One switch	10	3		10‡	3‡	-9810	-9810	-10		
	DP-DT Two SPDT switches	2	2		0.4**	0.25**	-1006	-1006	-06		
SP-DT One switch	2	2		0.4**	0.25**	-1010	-1010	-10			

* Electrically Independent † Available on special order. Change 1st digit in Ordering Code from 4 to 5 or 7 to 8
‡ 10 Amp Inductive (Polarized) at 125 VDC
** Resistive ◊ 30 VDC = 5 Resistive i.e. -4820 becomes -5820, -7810 becomes -8810, etc.

Chart C

Series	Mounting Style	Minimum Specific Gravity	Pressure Rating At		Flange Class (psi)	Order Code
			38°C 100°F	246°C 475°F		
225	1" NPT	.75	600 psi	500 psi	-	C1-75
			41 bar	34 bar		
225	1" NPT	.80	1000 psi	750 psi	-	C1-80
			69 bar	52 bar		
227	FLANGED	.75	275 psi	100 psi	150	C1-175
228			19 bar	7 bar		
227	FLANGED	.80	275 psi	100 psi	150	C1-180
228			19 bar	7 bar		
227	FLANGED	.75	600 psi	425 psi	300	C1-375
228			41 bar	29 bar		
227	FLANGED	.80	720 psi	425 psi	300	C1-380
228			50 bar	29 bar		
227	FLANGED	.75	600 psi	500 psi	600	C1-675
228			41 bar	34 bar		
227	FLANGED	.80	1000 psi	750 psi	600	C1-680
228			69 bar	52 bar		

LEVEL Float Level Switches,