



Series  
221

# Flanged Chamber

External Mount, Pressure to 1000 psig (69 bar) and  
Temperature to 475°F (246°C), Hermetically Sealed Switches



Series 223 has one vertical and one horizontal flanged connection (1" RF forged steel - ANSI specifications). Flange centerline 14" (356 mm). Other centerlines available.

Series 224 has one vertical and one horizontal flanged connection (1" RF forged steel - ANSI specifications). Flange centerline 14 5/8" (371 mm). Other centerlines available.



Series 221 features one vertical and one horizontal 1" NPT pipe connection. Optional, 1" socket weld.

"A" is the level at which single (or lower stage) operates on level rise.

"B" is the operating differential single (or lower stage) - drop in level to restore switch to original position.

"C" is the level at which the upper stage operates on level rise.

"D" is the operating differential of upper stage - drop in level to restore switch to position.

"E" - the increase in level above "A" to operate upper stage.

Repeatability ± 1/4" (6.4 mm)

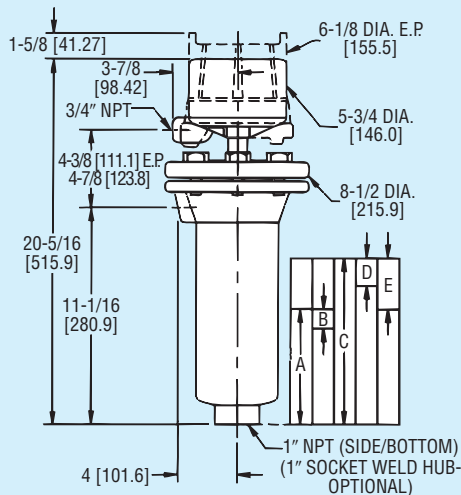

## Switch Level Change Single Stage Operation

## Switch Level Change Two Stage Operation

	SP GR	A*	B	A**	B	C	D	E	ORDERING CODE
MIN SP GR 0.6 600 PSI (41 BAR) @ 100°F (38°C) 550 PSI (38 BAR) @ 475°F (246°C)	1.0	6 3/4" (171 mm)	3/4" (19 mm)	5 3/4" (146 mm)	3/4" (19 mm)	7 3/4" (197 mm)	1" (25.4 mm)	2" (51 mm)	C1-60
	0.6	7 1/2" (191 mm)	1" (25.4 mm)	6 1/2" (165 mm)	1" (25.4 mm)	9" (229 mm)	1 3/4" (44 mm)	2 1/2" (64 mm)	
MIN SP GR 0.75 1000 PSI (69 BAR) @ 100°F (38°C) 850 PSI (59 BAR) @ 475°F (246°C)	1.0	7 1/4" (184 mm)	3/4" (19 mm)	6 1/4" (159 mm)	3/4" (19 mm)	8 1/2" (216 mm)	1 1/4" (32 mm)	2 1/4" (57 mm)	C1-75
	0.75	8" (203 mm)	1" (25.4 mm)	7" (178 mm)	1" (25.4 mm)	9 1/2" (241 mm)	1 3/4" (44 mm)	2 1/2" (64 mm)	

\*\*"A" is adjustable ± 1".

\*\*"A" is not adjustable.

**Heavy duty flanged chamber** features removable float for ease of inspection and maintenance. The 221 Series also provides 1" NPT for standard external mounting. Socket weld hubs or flanges are optional. Rugged C1-75 construction is suitable for operation at 1000 psi (69 bar) at 100°F (38°C), and 850 psig (59 bar) at 475°F (246°C) with a minimum specific gravity of 0.75. C1-60 construction is suitable for operation at 600 psig (41 bar) at 100°F (38°C), and 550 psig (38 bar) at 475°F (246°C) with a minimum specific gravity of 0.60. Models featured can be ordered with various circuits including SPST, SPDT, or DPDT with hermetically sealed snap action or mercury contacts. A full range of enclosures are available including general purpose, (weather-proof) (explosion-proof) (explosion-proof - vapor proof).

## APPLICATIONS

Oil refineries, chemical plants, power generating stations, pumping stations, heat transfer systems, sanitary/waste water facilities, drip legs, hydraulic systems, boilers.

## SPECIFICATIONS

**C1-60:** Minimum specific gravity 0.60. Process pressure 600 psig (41 bar) at 100°F (38°C), 550 psig (38 bar) at 475°F (246°C).

**C1-75:** Minimum specific gravity 0.75. Process pressure 1000 psig (69 bar) at 100°F (38°C), 850 psig (59 bar) at 475°F (246°C).

**Switch Type:** Snap action or mercury switch.

**Electrical Rating:** See charts A and B.

**Wiring Connections:** G, WT or E enclosure, terminal block. EV enclosure, 18" (460 mm) leads.

**Process Connections:** 1" NPT standard (socket weld hubs or flanges optional). See chart C.

**Enclosures:** G, painted steel and aluminum. WT, painted steel, aluminum and neoprene. E, aluminum. EV, aluminum and neoprene.

**Wetted Parts:** Chamber, carbon steel. Trim 316SS, 303SS, 304SS and 430SS.

**Weight:** 221, 60 lb (27 kg); 223, 70 lb (32 kg); 224, 77 lb (35 kg).

## Suggested Specifications:

Liquid level control shall be 221 (223) (224) Series with flanged carbon steel chamber, and removable float. Process connections shall be 1" NPT (socket weld hubs) (flanged). Control shall be suitable for operation at 600 psig (41 bar) at 100°F (38°C), and 550 psig (38 bar) at 475°F (246°C) with a minimum specific gravity of 0.60 (C1-60); or 1000 psig (69 bar) at 100°F (38°C), and 850 psig (59 bar) at 475°F (246°C) with a minimum specific gravity of 0.75 (C1-75). Circuit shall be (hermetically sealed) snap action (mercury) switch (SPST) (SPDT) (DPDT) with fixed deadband. Switch mechanism shall be gravity return and shall be activated by a stainless steel float. Enclosure shall be general purpose, (weatherproof) (explosion-proof) (explosion-proof - vapor proof).

Level

**MODEL CHART – SERIES 221**

<b>EXAMPLE</b>	221	WT	7810	10	HF	C1	60			221-WT-7810-C1-60. Liquid level control. Flanged carbon steel chamber. Weather proof enclosure. SPDT snap switch, fixed deadband, automatic reset. Operating pressure 600 psig (41 bar at 100°F (38°C), 550 psig (38 bar) at 475°F (246°C). Side/bottom process connections. 1" NPT hubs. Minimum specific gravity 0.60.		
<b>ENCLOSURE</b>		G WT E  EV								General purpose, NEMA-1. Weatherproof, NEMA-3R, 4, 4X. Explosion-proof, NEMA-7, 9. Class I Groups B, C, D. Class II Groups E, F, G. (CSA approved Groups C, D, E, F, G only). Explosion proof, vapor proof, NEMA-7, 9. Class I Groups B, C, D. Class II Groups E, F, G (CSA approved groups C, D, E, F, G only).	UL UL UL	CSA CSA CSA
<b>CIRCUITS</b>  (For Electrical Circuits see charts A & B below.)			48XX 48XX 78XX 78XX 78XXHM 98XX  98XX  10XX  10XX	XX  XX  XX  XX						Single stage. Mercury switch. See Chart A. Two stage. Mercury switch. See Chart A. Single stage. Snap switch. See Chart B. Two stage. Snap switch. See Chart B. Hermetically sealed snap switch. See Chart B. Single stage. High capacity DC snap switch. Use heat fins (HF) if process temperature exceeds 350°F (177°C). Do not exceed 450°F (232°C). See Chart B. Two stage. High capacity DC snap switch. Use heat fins (HF) if process temperature exceeds 350°F (177°C). Do not exceed 450°F (232°C). See Chart B. Single stage. High temperature snap switch. Continuous rating 800°F (425°C). See Chart B. 221-C1-60 type rated at 350 psig (25 bar); 221-C1-75 type rated at 550 psig (38 bar). Two stage. High temperature snap switch. Continuous rating 800°F (425°C). See Chart B. 221-C1-60 type rated at 350 psig (25 bar); 221-C1-75 type rated at 550 psig (38 bar).		
<b>FLANGED CHAMBER CONSTRUCTION 1" NPT HUBS</b>	221 221					C1 C1 C1	60 60 75			Refer to Chart C for pressure/temperature ratings. Carbon steel chamber. Minimum specific gravity 0.60. Side/bottom process connections. 1" NPT hub. Minimum specific gravity 0.75. Side/bottom process connections. 1" NPT hub.	UL UL UL	CSA CSA CSA
<b>FLANGED CHAMBER CONSTRUCTION WITH FLANGED PROCESS CONNECTIONS</b>	223 223 223 223 223 223 224 224 224 224 224 224					C1 C1 C1 C1 C1 C1 C1 C1 C1 C1 C1 C1	160 360 660 175 375 675 160 360 660 175 375 675			Refer to Chart C for pressure/temperature ratings. 1" 150# flanges side/bottom process connection. 1" 300# flanges side/bottom process connection. 1" 600# flanges side/bottom process connection. 1" 150# flanges side/bottom process connection. 1" 300# flanges side/bottom process connection. 1" 600# flanges side/bottom process connection. 1" 150# flanges side/side process connection. 1" 300# flanges side/side process connection. 1" 600# flanges side/side process connection. 1" 150# flanges side/side process connection. 1" 300# flanges side/side process connection. 1" 600# flanges side/side process connection.	UL UL UL UL UL UL UL UL UL UL UL UL	CSA CSA CSA CSA CSA CSA CSA CSA CSA CSA CSA CSA
<b>OPTIONS</b>					HF			H2 12		High temperature fins should be considered if ambient temperature is extremely high or if process temperature exceeds 500°F (260°C) for extended periods. 1" socket weld hub instead of 1" NPT. Breather and drain for E type enclosure. Recommended for high humidity or outdoor service.		

Level

**CHARTS A & B - ELECTRICAL CIRCUITS AND RATINGS**

SWITCH TYPE	SWITCH ACTION	ELECTRICAL RATINGS IN AMPS					ORDERING CODE				
		AC		DC			SINGLE STAGE	TWO STAGE		UL	CSA
		120V	240V	440V	125V	250V		LOWER	UPPER		
<b>CHART A</b>	SP-ST Open on level FALL	10	5	3‡	10	5	-4821	-4821	-21	UL	CSA
	SP-ST Open on level RISE	10	5	3‡	10	5	-4820	-4820	-20	UL	CSA
	SP-DT One switch	4	2	1‡	4	2	-4810	-4810	-10	UL	CSA
	SP-DT Two switches E.I.*	10	5	3‡	10	5	-4815	-4815	-15	UL	CSA
	DP-ST Two switches E.I.* Open on level FALL	10	5	3‡	10	5	-4813	-4813	-13	UL	CSA
	DP-ST Two switches E.I.* Open on level RISE	10	5	3‡	10	5	-4814	-4814	-14	UL	CSA
	DP-DT Two SP-DT switches	4	2	1‡	4	2	-4806	-4806	-06	UL	CSA
<b>CHART B</b>	SP-DT One switch	12	5	3‡	0.5**	0.25**	-7810	-7810	-10	UL	CSA
	DP-DT Two SP-DT switches	12	5	3‡	0.5**	0.25**	-7806	-7806	-06	UL	CSA
	SP-DT One hermetically sealed switch**	5	5				-7810HM	-7810HM	-10HM		
	DP-DT Two hermetically sealed SP-DT switches**	5	5				-7806HM	-7806HM	-06HM		
	DP-DT Two SP-DT switches	10	3		10‡	3‡	-9806	-9806	-06		
	SP-DT One switch	10	3		10‡	3‡	-9810	-9810	-10		
	DP-DT Two SP-DT switches	2	2		0.4**	0.25**	-1006	-1006	-06		
SP-DT One switch	2	2		0.4**	0.25**	-1010	-1010	-10			

\*Electrically Independent  
‡10 Amp inductive (Polarized) at 125 VDC  
\*\*Resistive      \*\* 30VDC = 5 Resistive

‡Available on special order. Change 1st digit in Ordering Code from 4 to 5 or 7 to 8  
i.e. -4820 becomes -5820, -7810 becomes -8810, etc.

**CHART C**

SERIES	MOUNTING STYLE	MINIMUM SPECIFIC GRAVITY	PRESSURE RATING AT		FLANGE CLASS (psi)	ORDER CODE
			38°C 100°F	246°C 475°F		
221	1" NPT	0.6	600 psi 41 bar	550 psi 38 bar	-	C1-60
221	1" NPT	0.75	1000 psi 69 bar	850 psi 59 bar	-	C1-75
223 224	Flanged	0.6	275 psi 19 bar	150 psi 10 bar	150	C1-160
223 224	Flanged	0.6	600 psi 41 bar	550 psi 38 bar	300	C1-360
223 224	Flanged	0.6	600 psi 41 bar	550 psi 38 bar	600	C1-660
223 224	Flanged	0.75	275 psi 19 bar	150 psi 10 bar	150	C1-175
223 224	Flanged	0.75	720 psi 50 bar	625 psi 43 bar	300	C1-375
223 224	Flanged	0.75	1000 psi 69 bar	850 psi 59 bar	600	C1-675