

# MT712 Load Cell



<u>Features</u>	<u>Applications</u>
Hollow Structure	Process Control Devices
Tool Steel Construction	Rolling mills
Low Profile	Rope tension
Capacities from 0.5t to 300t	Force Measurements

## Specifications

Capacity	t	0.5, 1, 2, 3, 5, 10, 20, 50, 100, 200, 300 t
Combined Error	(%FS)	≤±0.1
Creep (30 minutes)	%FS/30min	≤±0.1
Temperature effect on sensitivity	(%FS/10C)	≤±0.05
Temperature effect on zero	(%FS/10C)	≤±0.1
Output sensitivity	(mv/v)	1.0±0.1
Input resistance	(Ω)	385+/-15
Output resistance	(Ω)	350+/-3.5
Insulation resistance	(MΩ)	≥ 5000 (50VDC)
Zero balance	(%FS)	2.0
Temperature, Compensated	(°C)	-10~+50
Temperature, Operating	(°C)	-20~+60
Excitation, Recommended	(V)	5~12(DC)
Excitation, Max	(V)	18(DC)
Safe overload	(%FS)	150
Ultimate overload	(%FS)	300



Millennium Mechatronics Limited  
 Email: [info@meltrons.com](mailto:info@meltrons.com) | [www.meltrons.com](http://www.meltrons.com)



# MT712 Load Cell

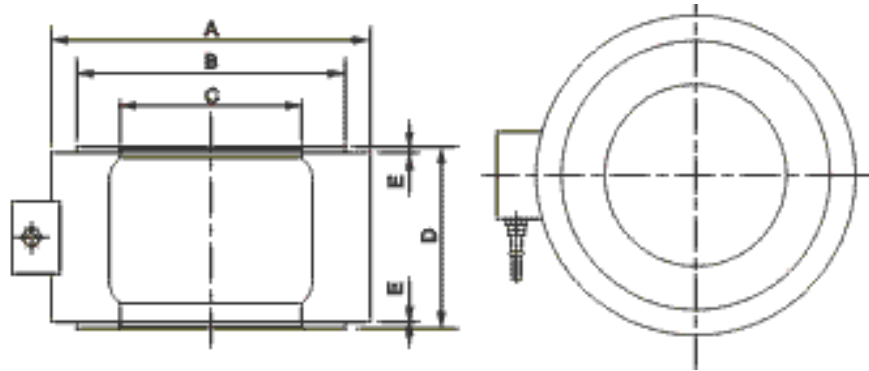

Capacity (t)	0.5t	1t	2t, 3 t	5t	10t	20t	50t	100t	200t	300t
Dim A	40	62	62	60	60	90	115	166	236	236
B	35	55	55	36	36	68	109	141	190	195
C	10	18	18	18	18	43	80	85	120	120
D	52	72	72	72	82	82	114	114	126	126
E	3	4	4	4	4	5	7	7	7	7

## Dimensions (mm)

### Cable

4 Core, 5.4 mm dia (3-300t) , 6m long

4 Core, 4 mm dia (0.5-2t) , 4m long

### Color Code

Exc+ Red, Exc- Black

Sig+ Green, Sig- White

Screen- Transparent

Specifications are subject to change without notice for improvement

MT712EV01-07012012



Millennium Mechatronics Limited  
Email: [info@meltrons.com](mailto:info@meltrons.com) | [www.meltrons.com](http://www.meltrons.com)

